



iJINUS
GROUPE CLAIRE

BLUE & BLUE-LP



Autonomous logger

User manual

User manual: Version 07

Date de publication 04/2026

Documentation valid from Avelour software version 7.4.1

Table des matières

1. Document informations	7
1.1. Context	7
1.2. Symbols used	7
2. Product marking information	8
3. Safety	9
3.1. General instructions	9
3.2. WARNING TO USERS IN CANADA / ATTENTION POUR LES UTILISATEURS AU CANADA	9
3.3. WARNING TO USERS IN THE UNITED STATES	10
4. Description	11
4.1. Principle	11
4.2. Equipement description	12
4.3. Technical characteristics	13
4.3.1. Logger	13
4.3.2. Dimensions	14
4.3.3. Pressure sensor	14
4.3.4. Blue - M12 12 Pin Connector	15
4.3.5. Blue-LP - M12 12 Pin Connector	15
5. Getting started	17
5.1. Setting up a SIM card	17
5.1.1. Discharging electrical charge	17
5.1.2. Inserting a SIM card	17
6. Electrical supply	19
6.1. Using a mains power supply	19
6.2. Using an external battery	19
7. Connection	20
7.1. Connecting an external sensor	20
7.2. Wiring	20
7.2.1. Flow meter wiring in Modbus protocol	20
Krohne Waterflux 3070	20
ABB Aqua master 4	21
Badger M5000	21
MAG8000	22
Octave	22
Proline Promag W 800	23
7.3. Connecting a 2 wires sensor	25

7.4. Connecting a 3 wires sensor	25
7.5. Connecting a 3 wires sensor with a power supply	26
7.6. Connecting a hose to the internal pressure sensor (LP version)	26
8. Installation	27
8.1. Outdoor	27
8.2. Mounting the logger	27
8.3. Installing a remote antenna	28
9. Configuring on Avelour	30
9.1. Equipement required	30
9.2. Installing Avelour software	30
9.3. Connecting to the logger	30
9.4. Protect the logger using a password	31
9.4.1. Activation	31
9.4.2. Password Format	33
9.4.3. Forgotten password	33
9.5. General configuration information	33
9.6. Configuring a measurement recording	34
9.6.1. Chlorine Mesurement via sensor Halogen MP5-A	34
Principle	34
Measurement range	34
Configuration	34
9.6.2. Turbidity measurement using the LowTus probe	39
Principe	39
Configuration	39
9.6.3. Conductivity measurement via B&C sensor	42
Principle	42
Settings	42
9.6.4. Measurement using the Modbus protocol : Slave mode	44
Principle	44
Settings	45
9.6.5. Measurement via 4 digital inputs	46
Principle	46
Configuration	46
9.6.6. Modbus flow meter	58
Principle	58
Flowmeter wiring	58
Configuration	58
9.6.7. Modbus master	67
Principle	67
Configuration	67
9.6.8. Measurement using a 4-20 mA signal	70
Principle	70
Settings	70
Table of correspondences	76
9.7. Configuring the sending data	77
9.7.1. Technologies used	77
9.7.2. Signal quality: Mobile Signal Strength Value	77

9.7.3. Configuring the modem of the communication card	78
Technology to use	79
PIN code	79
APN	80
Priority operator (Multi-operator SIM)	80
Program modem	81
9.7.4. Check network quality: Modem diagnostics	82
9.7.5. Data sending in FTP(s)	83
9.7.6. Data sending in Http(s)	86
Configuration	86
9.7.7. Data sending in MQTT(s)	89
Principle	89
Message format	89
Activation	89
Configuration	90
Quality of Service (advanced setting)	90
Format Almayiva	90
Topic (advanced setting)	91
9.7.8. Advanced internet connection settings	91
PPP	91
SNTP	91
Custom DNS server	92
9.7.9. Certificate management	92
Generalities	92
Managing certificate	93
9.7.10. Data sending via SMS	94
9.7.11. Data sending in LoRaWAN	96
Transmission cycle	96
Login information	96
Test data transmission	96
Advanced settings	97
Expert mode	97
Integration of a logger on Orange Live objects	97
Integration of a logger on WIOTYS	98
Integration of a logger on THE THINGS	98
9.7.12. Configure an alarm	100
9.7.13. Sending an alert SMS	100
9.8. Sending logger configuration using server (remote configuration)	100
9.8.1. Principle	100
9.8.2. Configuring server access on Avelour	101
FTP	101
HTTP	102
MQTT	103
9.8.3. Configuring data sending	104
FTP	104
HTTP	104
MQTT	105
9.8.4. Retrieving a configuration via internet	105
9.8.5. Edit and send the configuration remotely	107
9.8.6. Do a remote configuration of a logger without a communication card	108
9.9. Test data transmission before commissioning	109
9.9.1. Objective	109
9.9.2. Test procedure	110
9.9.3. Troubleshooting	110

9.10. Power supply configuration	111
9.10.1. Lithium battery	111
9.10.2. Lead-acid battery	112
9.11. Set time zone	112
9.12. Pairing one or more loggers	113
9.13. Check the status of data recording and transmission	114
9.14. Save the configuration to the logger	115
9.15. Viewing measured data in real-time	116
9.16. Configuration managing	116
9.16.1. Creating a configuration template	116
9.16.2. Applying a template configuration	117
9.16.3. Archiving a configuration file	117
9.17. Stopping a recording in progress	118
9.18. Disconnecting from the logger	118
10. Managing recorded data on Avelour	119
10.1. Retrieving recorded data (Auxilliary memory)	119
10.2. Retrieving recorded data (Main memory)	119
10.3. Displaying data on graph window	121
10.4. Data graph	121
10.4.1. Tools graph on Avelour	121
10.4.2. Displaying the data graph	122
10.4.3. Customising the graph display	122
10.4.4. Hide the display of a data item on the graph	123
10.4.5. Displaying table data	124
10.5. Exporting retrieved data	124
10.6. Delete data memory on the logger	125
11. Maintenance	126
11.1. Replace the battery	126
11.2. Reset the logger (factory settings)	128
11.2.1. Wiji reset	128
11.2.2. Manual reset	129
11.3. Firmware update	130
11.4. Remote firmware update	131

Chapitre 1. Document informations

1.1. Context

This user guide contains information required for installing, connecting and configuring your device, as well as important maintenance notes.

It is therefore essential you read it before installing a piece of Ijinus product.

1.2. Symbols used



This symbol indicates a situation or use that could lead to damage, fault or malfunction of the product.



This symbol indicates additional information useful for understanding and using the product correctly.



This symbol indicates a prerequisite for carrying out a procedure.

Chapter 2. Product marking information



The CE mark indicates that the product complies with current European directives.



Consult the user manual before using the product.



Do not dispose of this product in household waste. The product must be sent to a specific collection point, or collected by an organization that will ensure its further processing.



Direct current

Meaning of symbols

Chapitre 3. Safety

3.1. General instructions

This document presents various manipulations and programming operations to be carried out on a logger, sensor or accessory provided by Ijinus. These manipulations should only be carried out by people trained to use Ijinus products.

The instructions given in this user guide will only ensure operational safety if the equipment is used in line with these instructions.

You must use the appropriate personal protective equipment whenever you intervene on the device.

Below is a non-exhaustive list of recommendations to be followed to ensure the safety of Ijinus logger users:

- Only use batteries referenced by Ijinus.
- Fire or burn hazards with the lithium battery supplied by Ijinus: Do not make a short-circuit, or recharge, puncture, incinerate, crush, submerge, fully discharge, or expose the batteries to temperatures above the operating temperature range.
- Do not shake the logger.
- Do not physically modify the logger.
- Do not clean with an aggressive product, especially acetone and similar products.
- The device contains components that can be damaged or destroyed by electrostatic discharges. Discharge the electrical charges from your body before opening the logger and handling it. To do this, touch a grounded metal surface.

Ijinus accepts no liability for any damage resulting from improper use.

3.2. WARNING TO USERS IN CANADA / ATTENTION POUR LES UTILISATEURS AU CANADA

This device complies with Industry Canada license-exempt RSS standard(s). Operation is subject to the following two conditions: (1) this device may not cause interference, and (2) this device must accept any interference, including interference that may cause undesired operation of the device.

Under Industry Canada regulations, this radio transmitter may only operate using an antenna of a type and maximum (or lesser) gain approved for the transmitter by Industry Canada.

To reduce potential radio interference to other users, the antenna type and its gain should be so chosen that the equivalent isotropically radiated power (e.i.r.p.) is not more than that necessary for successful communication.

This device complies with Industry Canada RF radiation exposure limits set forth for general population (uncontrolled exposure). This device must be installed to provide a separation distance of at least 20cm from all persons and must not be collocated or operating in conjunction with any other antenna or transmitter.

/

Le présent appareil est conforme aux CNR d'Industrie Canada applicables aux appareils radio exempts de licence.

L'exploitation est autorisée aux deux conditions suivantes : (1) il ne doit pas produire de brouillage, et (2) l'utilisateur du dispositif doit être prêt à accepter tout brouillage radioélectrique reçu, même si ce brouillage est susceptible de compromettre le fonctionnement du dispositif.

Conformément à la réglementation d'Industrie Canada, le présent émetteur radio peut fonctionner avec une antenne d'un type et d'un gain maximal (ou inférieur) approuvé pour l'émetteur par Industrie Canada.

Dans le but de réduire les risques de brouillage radioélectrique à l'intention d'autres utilisateurs, il faut choisir le type d'antenne et son gain de sorte que la puissance isotrope rayonnée équivalente (p.i.r.e.) ne dépasse pas l'intensité nécessaire à l'établissement d'une communication satisfaisante.

Le présent appareil est conforme aux niveaux limites d'exigences d'exposition RF aux personnes définies par Industrie Canada. Cet appareil doit être installé afin d'offrir une distance de séparation d'au moins 20cm avec l'utilisateur, et ne doit pas être installé à proximité ou être utilisé en conjonction avec une autre antenne ou un autre émetteur.

Si l'antenne est amovible (CNR-GEN) : This device has been designed to operate with the antenna(s) listed below, and having a maximum gain of 0dBi.

Antennas not included in this list or having a gain greater than 0dBi are strictly prohibited for use with this device. The required antenna impedance is 50 ohms.

List of acceptable antenna(s):

- IJINUS - B0E type

Ce dispositif a été conçu pour fonctionner avec les antennes énumérées ci-dessous et ayant un gain maximal de 0dBi.

Les antennes non incluses dans cette liste ou dont le gain dépasse 0dBi sont strictement interdites pour l'exploitation de ce dispositif. L'impédance d'antenne requise est 50Ω.

Liste des antennes acceptables :

- IJINUS - B0E type

3.3. WARNING TO USERS IN THE UNITED STATES

Federal Communication Commission Interference

Statement 47 CFR Section 15.105(b)

This equipment has been tested and found to comply with the limits for a Class B digital device, pursuant to Part 15 of the FCC Rules. These limits are designed to provide reasonable protection against harmful interference in a residential installation. This equipment generates uses and can radiate radio frequency energy and, if not installed and used in accordance with the instructions, may cause harmful interference to radio communications. However, there is no guarantee that interference will not occur in a particular installation. If this equipment does cause harmful interference to radio or television reception, which can be determined by turning the equipment off and on, the user is encouraged to try to correct the interference by one of the following measures:

- Reorient or relocate the receiving antenna.
- Increase the separation between the equipment and receiver.
- Connect the equipment into an outlet on a circuit different from that to which the receiver is connected.
- Consult the dealer or an experienced radio/TV technician for help.

Devices A0102 and H0102 complies with Part 15 of the FCC Rules. Operation is subject to the following two conditions: (1) This device may not cause harmful interference, and (2) this device must accept any interference received, including interference that may cause undesired operation.

NO UNAUTHORIZED MODIFICATIONS

47 CFR Section 15.21

CAUTION: This equipment may not be modified, altered, or changed in any way without signed written permission from IJINUS. Unauthorized modification may void the equipment authorization from the FCC and will void the IJINUS warranty.

This device complies with FCC RF radiation exposure limits set forth for general population (uncontrolled exposure). This device must be installed to provide a separation distance of at least 20cm from all persons and must not be collocated or operating in conjunction with any other antenna or transmitter.

Chapitre 4. Description

Compact and autonomous, the Blue logger allows you to set up a recording of many different parameters (pulse meter, Modbus flowmeter, 4-20mA pressure sensor, etc.).

The Blue logger can be equipped with two options: a built-in pressure sensor (LP option) and/or a cellular communication card (LTE option). The Blue logger is therefore available in four references:

- BLUE-80: Autonomous logger (local radio communication)
- BLUE-LP-80: Autonomous logger with internal pressure sensor (0-16 bar) and local radio communication
- BLUE-82-LTE: Autonomous logger, 2G/LTE-M/NB-IOT communication and local radio communication
- BLUE-LP-82-LTE: Autonomous logger with internal pressure sensor (0-16 bar), 2G/LTE-M/NB-IOT communication and local radio communication

4.1. Principle

Ijinus data loggers are designed to be autonomous and powered by a lithium battery. They record data from the equipment to which they are connected. A mobile programming unit (MOC00001) or a Wiji USB key (WIJIKEY-8) can be used to connect to the logger by radio (Wiji protocol), configure it and retrieve data locally. Depending on the model, the logger can be fitted with a modem so that data can be sent remotely, automatically and without a wired connection, to our web platform www.ijitrack.com or to a client server.

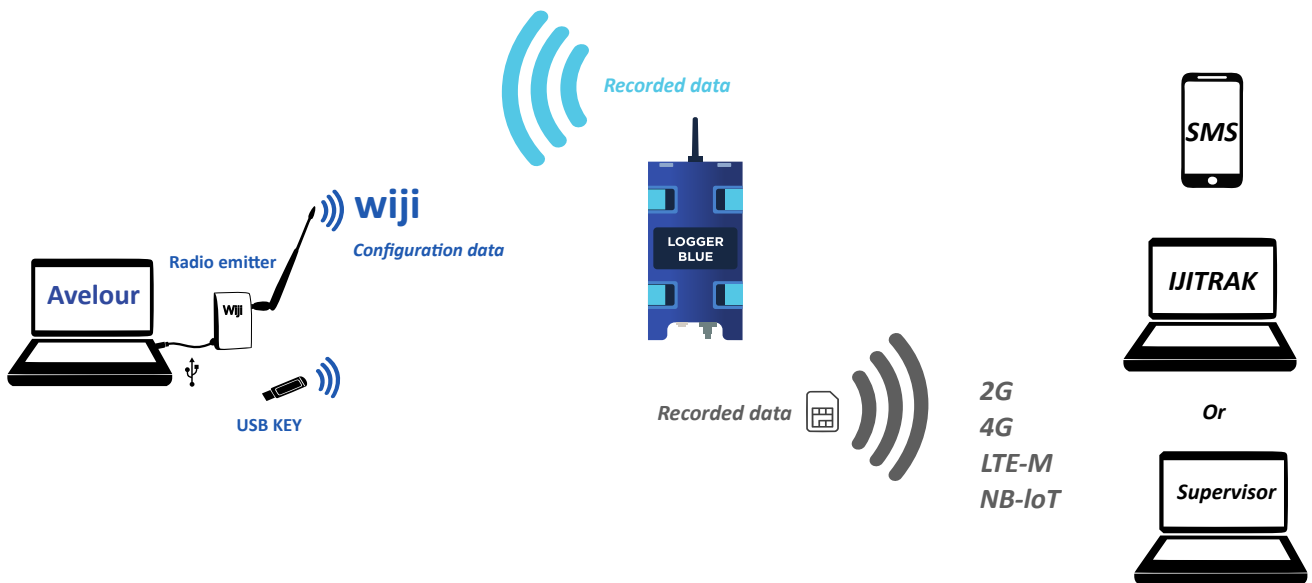

4.2. Equipement description

The Blue logger is powered by an internal battery. This logger's housing has IP68 sealing (immersion under 2m of water for 100 days). The Blue logger is equipped with a sensor to measurement water pressures between 0 and 16 bar.

A radio access point, also known as a programming antenna, is used to program the logger. This access point can also be used to download locally the data measured by the logger (a few dozen meters maximum between the logger and the access point connected to a computer's USB port).

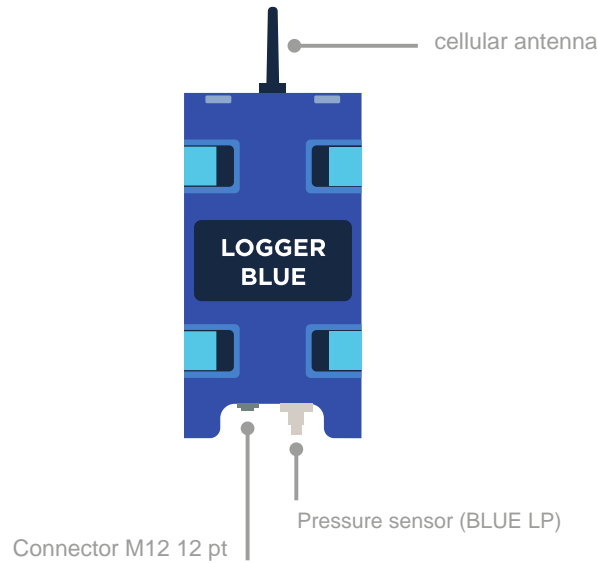

Blue logger



Non-rechargeable lithium battery 3.6 V 34 Ah



Programming antenna



External Antenna (Optional)





Mounting bracket



Connection Cable (if necessary)

4.3. Technical characteristics

4.3.1. Logger

Data Logger memory	500 000 measurements
Inputs	4x pulse inputs 100 Hz 2x 4-20mA inputs 1x RS485 Modbus inputs (if not used as output)
Outputs	1x Open collector 1x Modbus output (If not already used as input)
Connector	M12 12 points
Antennas : radio / cellular	Internal radio antenna, and internal / external cellular antenna
Communication protocols	FTPS, HTTPS, COAP or MQTTS
Logger Housing	PA12 50% glass fiber
Sealing grade	IP68 : 2m / 100 days (only if using an Ijinus mounting kit)
Power Supply	Internal : 3,6V 34 Ah lithium Battery - External : 7 ... 30 Vdc
Configuration	Wireless configuration kit (PN : MOC00001 or WijiKey) that includes the software AVELOUR
Dimensions and weight	224 x 116 mm for a thickness of 52,5 mm - 700 g (with battery and cellular card)
Operating T°	- 20 to + 70°C
Certifications	 

4.3.2. Dimensions

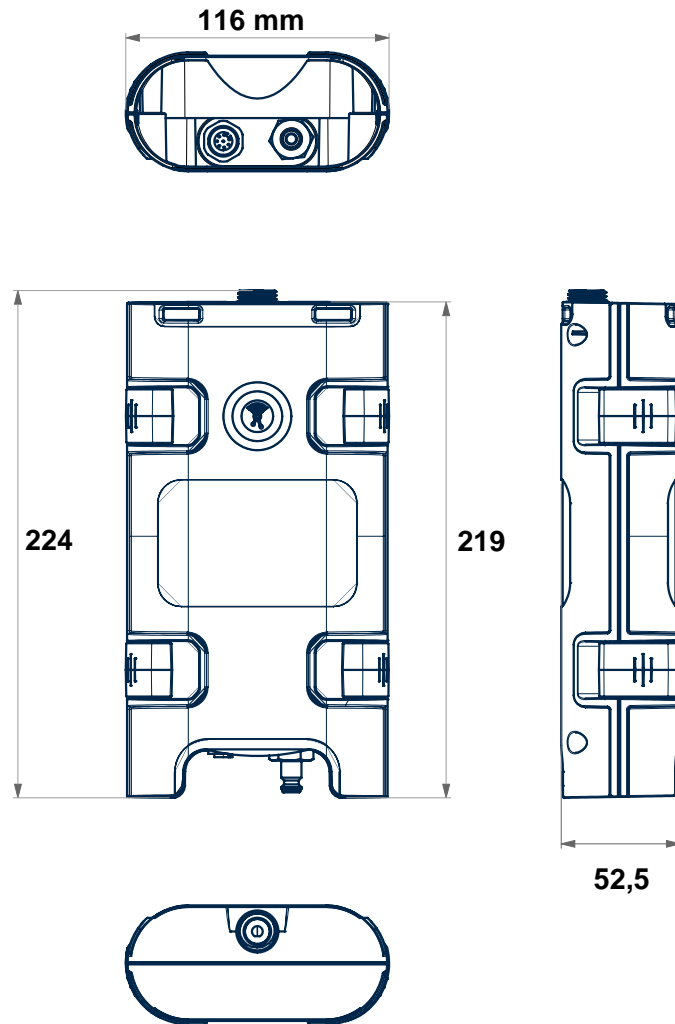





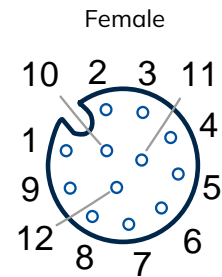
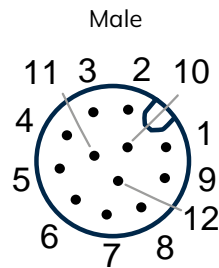

4.3.3. Pressure sensor

Logger pressure type	Absolute
Measuring range	0-16 bar
Test pressure	50 bar
Burst pressure	200 bar
Accuracy	≤ 0.3 % full scale
Operating / storage temperature	-30°C to + 85°C / -30°C to + 100°C
Certifications	NSF/ANSI 61/372 - MH60087









4.3.4. Blue - M12 12 Pin Connector

Wiring



Cable colors	Brown 	Blue 	White 	Green 	Pink 	Yellow 
PIN number	1	2	3	4	5	6
Signal	GND	AI 1	V in	V out	AI 2	Input or output
Features	Ground	Current 1	External power or battery (5V...30V)	Power 5V...18V* (internal battery) or Switch Vout=Vin	Current 2	RS485-H
Type		4-20 mA	Power Supply in	Power Supply out	4-20 mA	Modbus

* 1,8 W maximum on Vout, if external sensor connected and powered by internal battery (adjustable voltage by software).

Cable colors	Black 	Grey 	Red 	Purple 	Grey / Pink  / 	Blue / Red  / 
PIN number	7	8	9	10	11	12
Signal	DI 1	Input or output	Open drain output	DI 2	DI 3	DI 4
Features	Digital 1 / Counter 1 100 Hz	RS485-L	Ground contact	Digital 2 / Counter 2 100 Hz	Digital 3 / Counter 3 100 Hz	Digital 4 / Counter 4 100 Hz
Type	Digital	Modbus	Open drain (1A/30V)	Digital	Digital	Digital

4.3.5. Blue-LP - M12 12 Pin Connector

Male

Female

Wiring

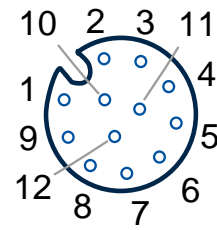
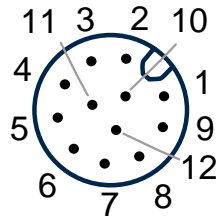

Cable colors	Brown ●	Blue ●	White ○	Green ●	Pink ●	Yellow ●
PIN number	1	2	3	4	5	6
Signal	GND	AI 2	V in	V out	AI 1	Input or output
Features	Ground	Current 2	External power or battery (5V...30V)	Power 5V...18V* (internal battery) or Switch Vout=Vin	Current 1	RS485-H
Type		4-20 mA	Power Supply in	Power Supply out	4-20 mA	Modbus

* 1,8 W maximum on Vout, if external sensor connected and powered by internal battery (adjustable voltage by software).

Cable colors	Black ●	Grey ●	Red ●	Purple ●	Grey / Pink ● / ●	Blue / Red ● / ●
PIN number	7	8	9	10	11	12
Signal	DI 1	Input or output	Open drain output	DI 2	DI 3	DI 4
Features	Digital 1 / Counter 1 100 Hz	RS485-L	Ground contact	Digital 2 / Counter 2 100 Hz	Digital 3 / Counter 3 100 Hz	Digital 4 / Counter 4 100 Hz
Type	Digital	Modbus	Open drain (1A/30V)	Digital	Digital	Digital

Chapitre 5. Getting started

If there is no cellular communication option, then there is no need to open the logger because the internal battery is already connected so the logger is directly functional.

Ijinus loggers do not require activation because they listen every 10 seconds for a radio connection request from a radio access point or another logger.

If the logger has a communication card (LTE option for example), then you must place the SIM card in the holder. [Setting up a SIM card](#).

5.1. Setting up a SIM card

loggers with a communication card need a SIM card to operate. The SIM card holder is located on the communication card, inside the logger.

5.1.1. Discharging electrical charge

Our sensors and loggers contain components that can be damaged by electrostatic discharges.



It is mandatory to discharge all charges from the body before opening the product.

To do this :

- Touch a grounded metal surface, such as the metal housing of an electrical cabinet.

5.1.2. Inserting a SIM card



When inserting the SIM card, it is essential not to leave the logger open for too long (just a few minutes) as the desiccant bags absorb the surrounding humidity and will no longer fulfil their role if they absorb too much.

- Open the case by unscrewing the 4 screws on the rear of the case and then unclipping the 4 clips from the front of the case.
- Insert the SIM card into the support provided for this purpose, taking care to respect the insertion direction. There is a diagram on the communication card showing this.

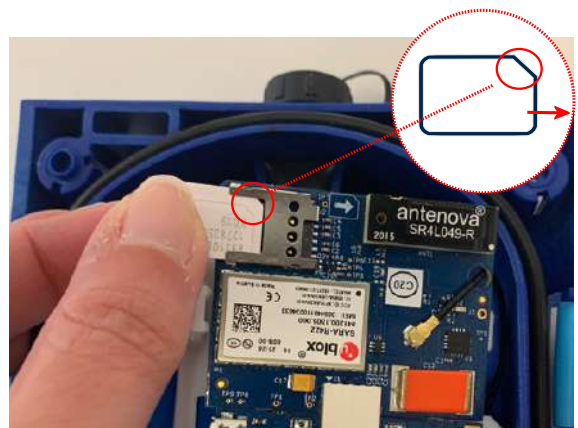

- Check the color of the desiccant bags and if they are green, replace them.

-
- Close the logger, taking care not to put any electrical wires or objects between the front of the case and the seal on the rear.
 - Reclip the 4 clips then, if necessary, retighten the 4 screws.



For outdoor installation, we strongly recommend that you use the 4 screws supplied with the logger to ensure that the casing is watertight and to prevent any deformation caused by temperature variations or bad weather.

Chapitre 6. Electrical supply

6.1. Using a mains power supply

It is possible to use an external mains power supply for IjInus loggers. The voltage supplied to the logger must be between 8V and 30V.



You must use a transformer (220V / 24V for example) equipped with a grounding system. In the absence of grounding, several malfunctions may occur (metering problems, measurement disturbances, etc.) related to the disturbances caused by the mains power supply.

- To configure the logger with Avelour software, refer to paragraph [Power supply configuration](#).

6.2. Using an external battery

There are two main types of battery available from IjInus:

- Rechargeable lead-acid battery
- non-rechargeable lithium battery.

Lead-acid batteries have a voltage of 12V.

Two types of lithium battery are available: 10.8V and 14.4V.



Do not use a 14.4V battery on a sensor other than the Nivus Doppler.

The use of a voltage higher than 13V on an Aqualabo sensor would result in the sensor being definitively damaged.

- To configure the logger with Avelour software, refer to paragraph [Power supply configuration](#).

Chapitre 7. Connection

7.1. Connecting an external sensor

The Blue logger has an M12 12-pin socket to connect different types of sensors or equipment. The Blue-LP model has an internal pressure sensor directly integrated into the housing.

To connect a sensor to the logger's M12 12-pin socket:

- Remove the protective cap and screw the sensor onto the connector.



To obtain IP68 sealing of the connector, make sure the connector is properly screwed onto the base. To do this, apply maximum hand tightening of the connector on the socket.

If several pieces of equipment need to be connected to the logger, then a junction box is available (reference GOD00051) in order to make this connection with IP68 sealing (subject to the correct tightening of all connectors).

- Connect the male connector to the logger socket and 3 sockets are then available on the junction box to connect sensors.

7.2. Wiring

The description of the 12-pin connector inputs/outputs, the colors of the wires and the associated functions is given in the following paragraph [Blue - M12 12 Pin Connector](#).

7.2.1. Flow meter wiring in Modbus protocol



For the flowmeter to operate correctly in the Modbus protocol of communication (see paragraph [Measurement using the Modbus protocol : Slave mode](#)), the ground must be wired.

Krohne Waterflux 3070

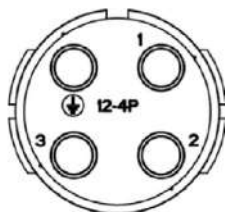

External side view connector

Flowmeter connector	wire Color	Function	M12 12 pts connector
1	Grey	RS485 L	8

Flowmeter connector	wire Color	Function	M12 12 pts connector
2	Yellow	RS485 H	6
3	NC	/	NC
4	Brown	GND	1

ABB Aqua master 4

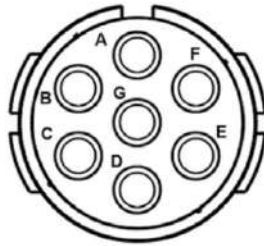

External side view connector

Flowmeter connector	Color	Function	M12 12 pts connector
A	Grey	RS485 L	8
B	Yellow	RS485 H	6
C	-	/	-
D	-	/	-
E	-	/	-
F	-	/	-
G	Brown	GND	1

Badger M5000

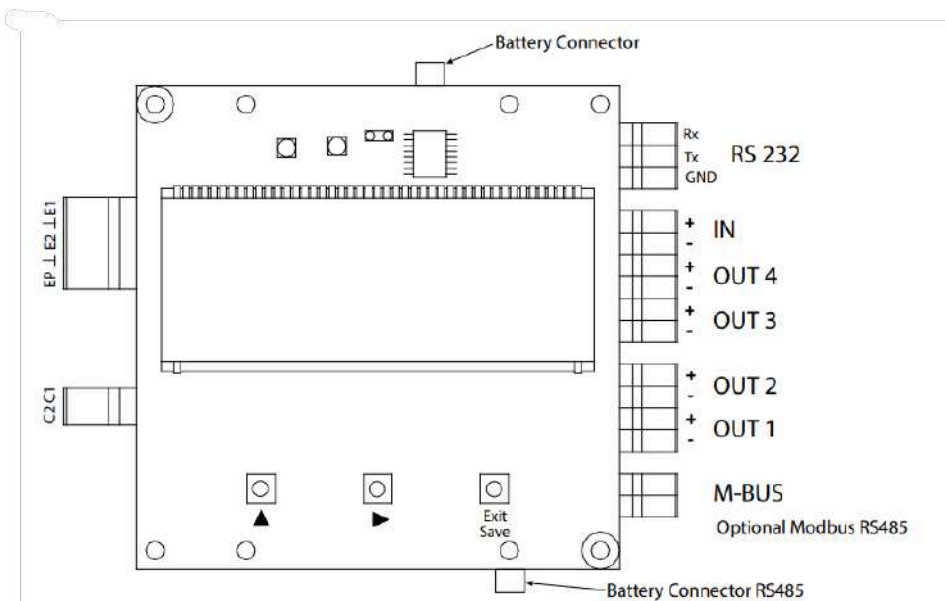

Input/Output	Description	Terminal
Output 1	Passive maximum 30V DC, 20 mA Maximum frequency 100 Hz	OUT1 (+) and (-)
Output 2	Passive maximum 30V DC, 20 mA Maximum frequency 100 Hz	OUT2 (+) and (-)
Output 3	Passive maximum 30V DC, 20 mA Maximum frequency 100 Hz	OUT3 (+) and (-)
Output 4	Passive maximum 30V DC, 20 mA Maximum frequency 100 Hz Can be used with digital input as an ADE interface.	OUT4 (+) and (-)
RS232	Modbus RTU	RxD, TxD, GND
IN	Digital input 3...35V DC	IN (+) and (-)
M-Bus ¹	M-Bus interface	No polarity
Optional Modbus RS485 ²	Modbus Interface Powered external 5...32V DC Optional internal by battery	GND, B-, A+, 12V

Flowmeter connector	Color	Function	M12 12 pts connector
A+	Yellow	RS485 H	4
B-	Grey	RS485 L	5
GND	Brown	GND	2

MAG8000

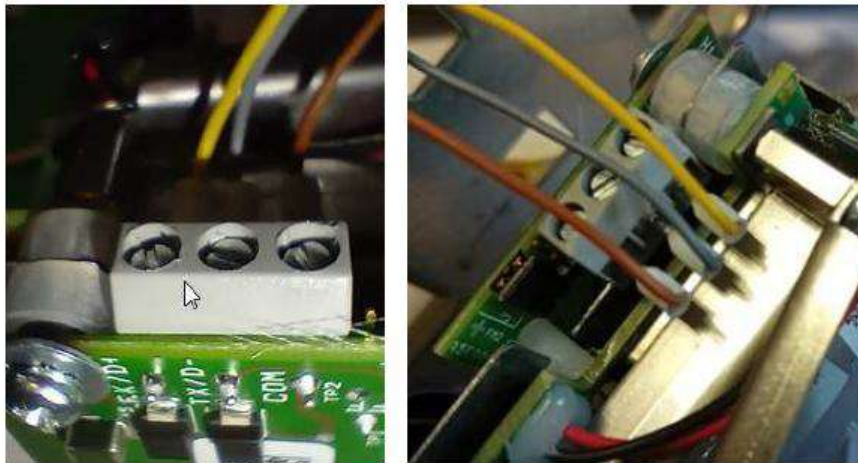

D+ : RS485 High (A) – IJINUS fil jaune
D- : RS485 Low (B) - IJINUS fil gris
COM : GND (fonctionne sans câblage de la masse) - IJINUS fil marron

Flowmeter connector	Color	Function	M12 12 pts connector
D+	Yellow	RS485 H	4
D-	Grey	RS485 L	5
GND	Brown	GND	2

Octave

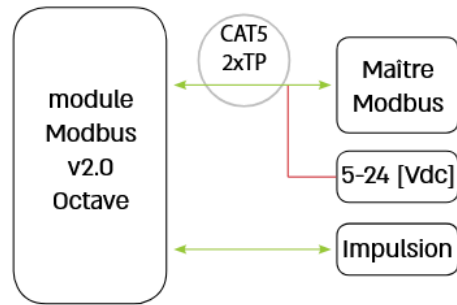

Câbles

	Fil	Fonction
ModBus	Bleu	D0/A/Tx+
	Blanc/Bleu	D1/B/Tx-
	Orange	5-24Vdc
	Blanc/Orange	Ground
Impulsion*	Rouge	Sortie impulsion
	Noir	Ground

MAG8000	Octave wire cable	IJINUS wire cable	Function	Pts connecteur M12 12 pts
Tx+	Blue	Yellow	RS485 H	4
Tx-	Blue/White	Grey	RS485 L	5
GND	Black	Brown	GND	2

Proline Promag W 800

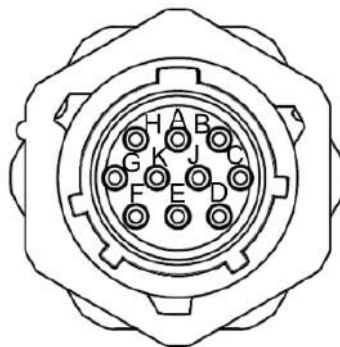

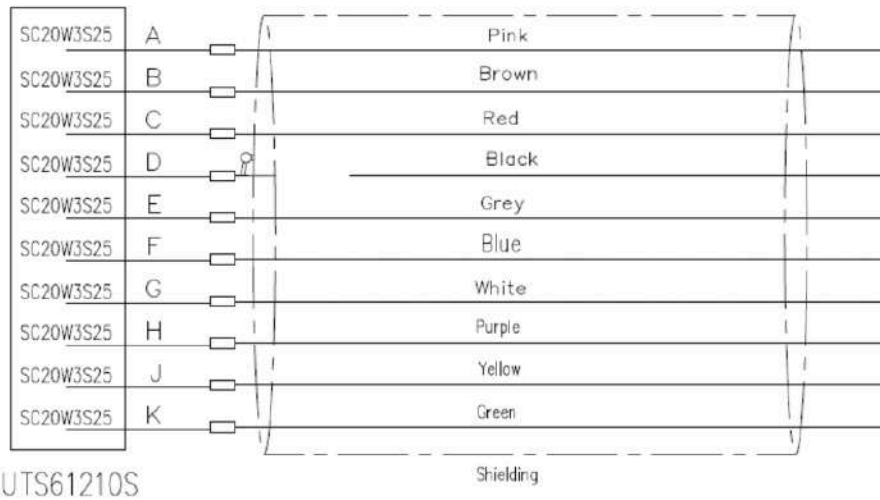

Broche	Fonction
A	PSO1+ (sortie impulsion/état 1+)
B	COM (potentiel de référence sorties impulsion/état)
C	NC (non connectée)
D	Terre
E	RS485_+ (Modbus B)
F	RS485_- (Modbus A)
G	PSO3+ (sortie impulsion/état 3+)
H	PSO2+ (sortie impulsion/état 2+)
J	NC (non connectée)
K	NC (non connectée)

MAG8000	IJINUS wire color	Fonction	M12 12 pts connector pts
E	Yellow	RS485 H	4
F	Grey	RS485 L	5
B	Brown	GND	2

7.3. Connecting a 2 wires sensor

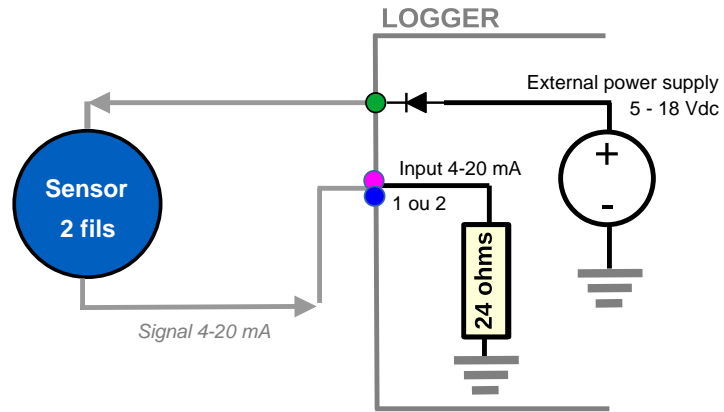

7.4. Connecting a 3 wires sensor

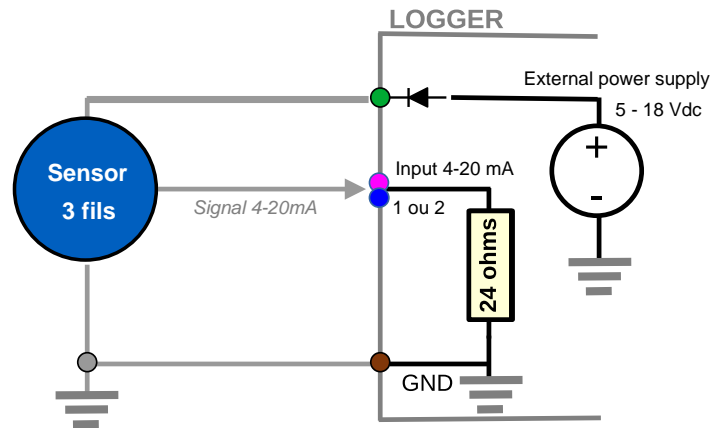

7.5. Connecting a 3 wires sensor with a power supply

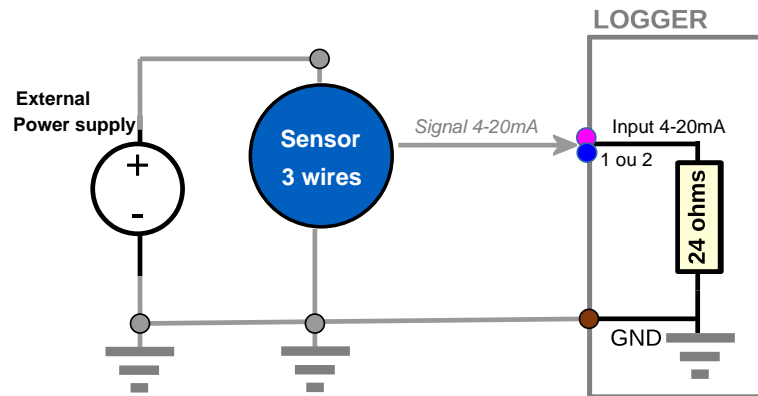

7.6. Connecting a hose to the internal pressure sensor (LP version)

The internal pressure sensor has a 1/4 Male Gas pressure connection to which a male quick coupling with a "European standard" profile is screwed.

- Clip a hose with a female quick coupling directly onto the integrated pressure sensor.



It is important that the hose that brings the water to the pressure sensor is purged of any air that may be inside.

Chapitre 8. Installation

8.1. Outdoor



For outdoor installation, we strongly recommend that you use the 4 screws supplied with the logger to ensure that the casing is watertight and to prevent any deformation caused by temperature variations or bad weather.

8.2. Mounting the logger

The two holes used to fix the bracket are oblong to allow you to adjust the horizontality of the two mounting brackets as well as possible.

Position the Blue logger on the bracket by "dragging and dropping". Two plastic pieces are included in the shipping box. By inserting them into the holes in the mounting bracket, they prevent the logger from falling off the bracket, in case the bracket is not fixed completely vertically. It is also possible to use a padlock or other device to secure the logger to its holder.



Mounting bracket



Installation



If you have to minimize the risk of theft of the logger, you can fix the bracket "upside down". If the logger is secured by a padlock, it will be more difficult to access the bracket mounting screws with this type of mounting.

The screws used to fix the bracket must be suited to the wall material. This is why no fasteners are included in the logger's shipping box.



Installation with padlocks

8.3. Installing a remote antenna

The use of a remote antenna is useful if the logger is installed in a manhole with a buffer. In this case, connection to the logger may not be possible.

You must use an Ijinus remote antenna. Three lengths are available as standard: 1, 3 or 5m. In exceptional cases, a length of 10m may be proposed.

The antennas are suitable for sewerage network applications with a thick cable and reinforced sealing

- Connect the antenna to the sensor by screwing it **firmly** by hand and all the way to ensure a good seal.
- Identify the best conditions for installing the antenna, particularly the drilling direction for the best communication quality. A positioning and data transmission test is available in the Avelour software. You must do this test before and after installation (cover closed in the case of a manhole).
- Drill so that the antenna is outside the base area.

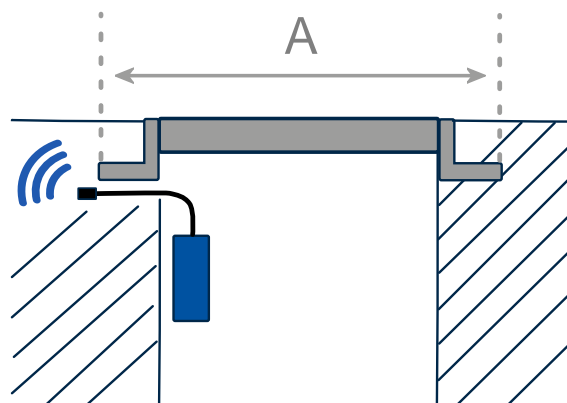

- Test positioning and data transmission using the Avelour software. This test should be carried out before and after installation (closed plug in the case of a manhole).



Drilling into the manhole



Inserting antenna under the base

Chapitre 9. Configuring on Avelour

9.1. Equipement required

- Avelour software version 7.1 or higher.
- A Wiji radio antenna in "long range" or "USB key" format.

9.2. Installing Avelour software

Avelour software can be downloaded from the Ijinus website (www.ijinus.com) in the "Download" section.

9.3. Connecting to the logger

- Connect the Wiji radio with its antenna (or the Wiji USB key) to your computer's USB port.
- Position the Wiji antenna more than one meter from the logger.
- Run the Avelour software.
- Open the logger selection window by clicking on "Connect to a wireless device".



- Select the logger identified by its serial number (refer to its nameplate) and click "ok".



Serial number on the nameplate

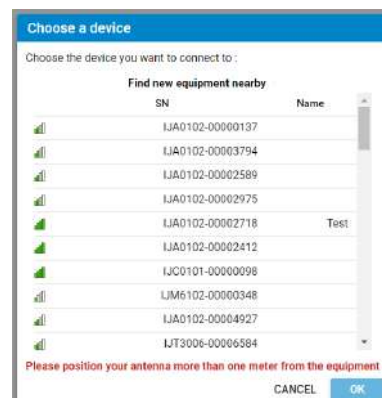

-> The logger configuration window opens.

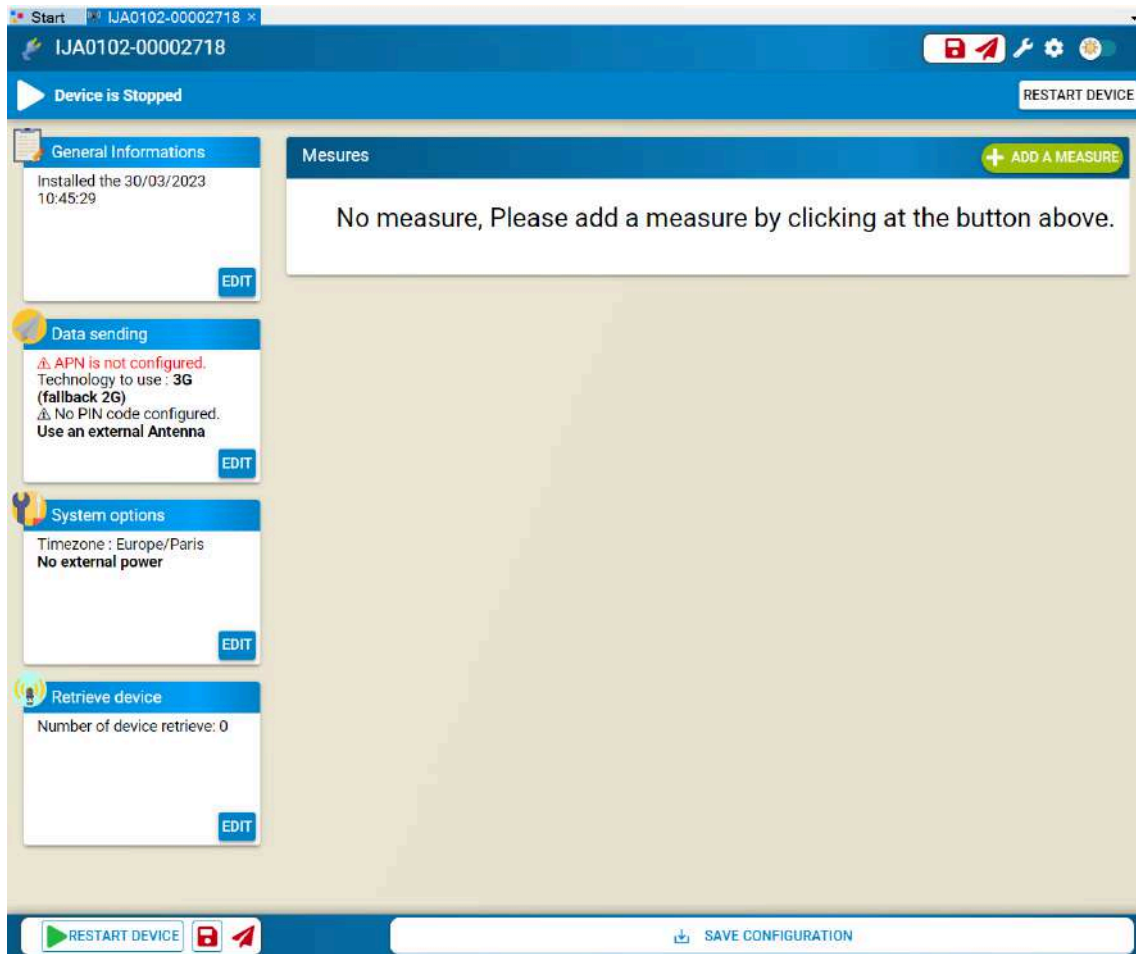

Logger configuration window S/N: IJA0102-00002718

-> A configuration file is automatically created.

Saved devices						
name	First	Last	Data ty...	Records	Creation	Retrieval
Devices						
IJA0102-00002718 (...)	11/06/20...	24/06/20...				
Configurations	21/06/20...	24/06/20...				24/06/...
Config 24/06/2...	24/06/20...				21/06/20...	24/06/...
Config 21/06/2...	21/06/20...				21/06/20...	21/06/...
Config 21/06/2...	21/06/20...				21/06/20...	21/06/...

Configuration file in the "Saved devices" data tree

9.4. Protect the logger using a password

9.4.1. Activation



To activate the protection, the latest firmware version and at least version 7.3 of Avelour must be installed.

By default, password protection is not active.

To activate it:

- In the system options, click on **Activate**  and enter the following password using the required format (see [Password Format](#) paragraph).

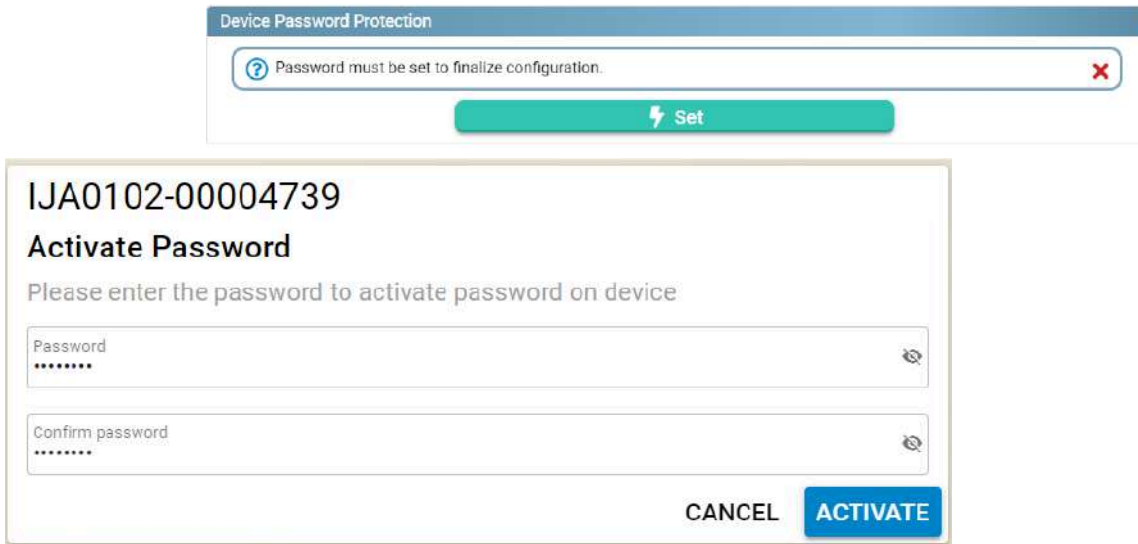

Password input and confirmation window

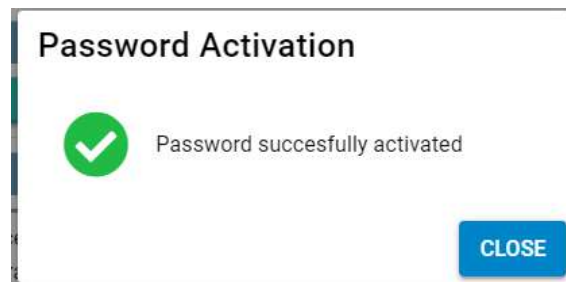

-> A temporary password is saved in Avelour for the current session and as long as Avelour is not closed, the password is not requested again.

-> After 3 failed attempts, you must redo the connection process from the start.

-> The Password is required to review the configurations that were generated while the password was activated (presence of a padlock).

IJA0102-00004708	12/05/20...
Configurations	12/05/20...
Config. 13/05/2025 16:24:...	13/05/20...
Config. 13/05/2025 16:21:...	13/05/20...
Config. 13/05/2025 14:30:...	13/05/20...
Config. 13/05/2025 14:30:...	13/05/20...
Config. 13/05/2025 08:50:...	13/05/20...
Config. 13/05/2025 08:47:...	13/05/20...
Config. 13/05/2025 08:47:...	13/05/20...
Config. 12/05/2025 17:12:...	12/05/20...

Password-locked configuration files

9.4.2. Password Format

The rules for the password format are as follows:

- Maximum length of 64 characters.
- Characters NOT allowed: **Space, accent and cedilla** .
- Minimum length: 1 character.
- No restrictions on the combination of characters.

9.4.3. Forgotten password

In case of a forgotten password:

- Manually reset the logger. (see [Manual reset](#)).



A manual reset deletes all settings and data files stored on the logger.

9.5. General configuration information

Editing the general information parameters allows you to input information concerning the identification of the logger, the measurement point, the date and any comments.

- Click on "Edit" and enter the required information if necessary.

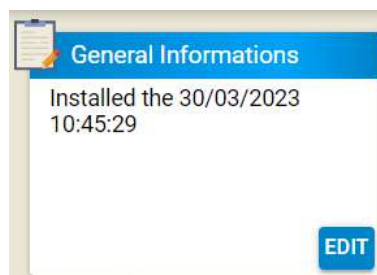

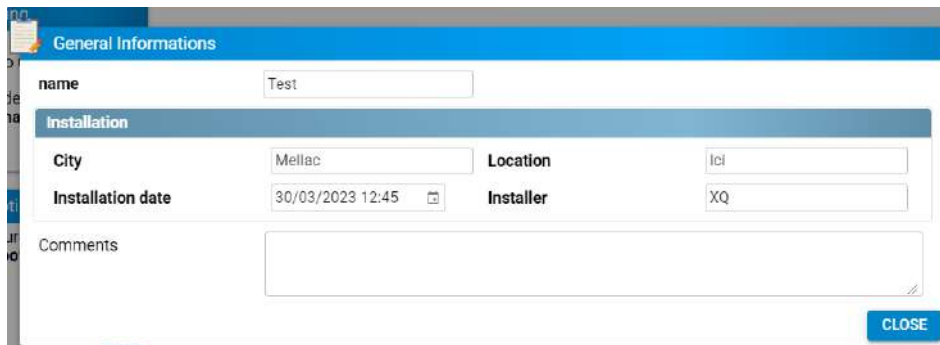

General information editing window

9.6. Configuring a measurement recording

9.6.1. Chlorine Measurement via sensor Halogen MP5-A

Principle

The Halogen MP5-A sensor measures five parameters and amperometric chlorine without membranes or reagents. The MP5-A does not require waste flow and can be used in many installation and monitoring configurations without being affected by flow rate or pressure. Compliant with EPA Method 334.0, the MP5-A sensor can be used to report residual chlorine measurements.

Measurement range

Range is 0 to 20 ppm

Configuration



Prerequisites: In Avelour, the Wiji connection to the logger must be established, see [Connecting to the logger](#).

In the recorder configuration window:

- Click  to add a measurement and select “MP5 Halogen Chlorine Sensor.”

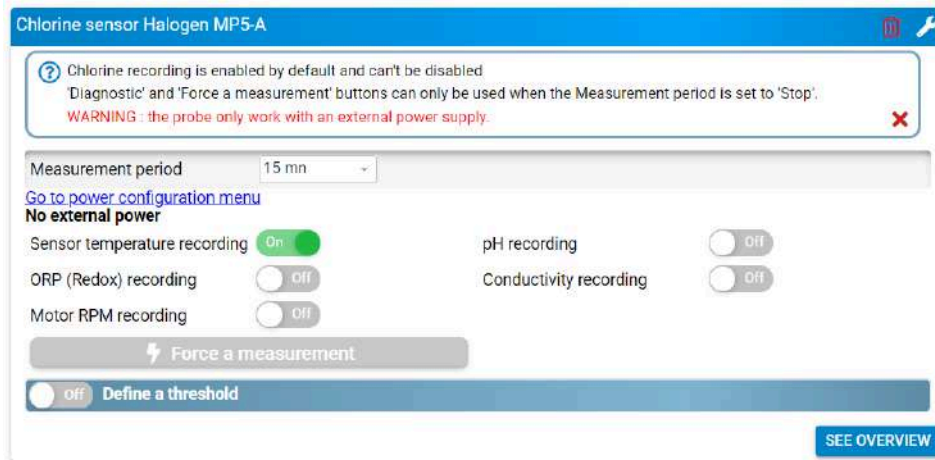

Halogen MP5 Chlorine Sensor parameters



Chlorine measurement recording is enabled by default and cannot be disabled.

The probe only works with an external power supply.

The 'Force Measurement' and 'Diagnostics' buttons can only be used when the Measurement Period is set to 'Off'.

Preheating time and measurement duration (advanced settings)

- Click on  to display the advanced settings for adjusting the probe **Preheat time** and the **Measurement duration**.



The cumulative duration must be adapted to the measurement period.



Saved parameters

- Enable data recording if necessary **ORP, pH, conductivité & vitesse moteur**.



The activated parameters will be available as threshold parameters. [la section intitulée « Set a threshold »](#).

Identify the Probe (advanced settings)

- Stop the measurement period and click on  to display **Probe Diagnostic**.
- Click on **Execute**  to display the firmware version and the serial number of the probe.

Valve control (advanced settings + expert mode)

- Switch to expert mode.
- Click on  to activate the valve control.



The measurement, which lasts approximately 1 minute and 30 seconds by default, will be launched at the end of the delay before the measurement.

The sum of the time before and after the measurement cannot exceed the measurement period.

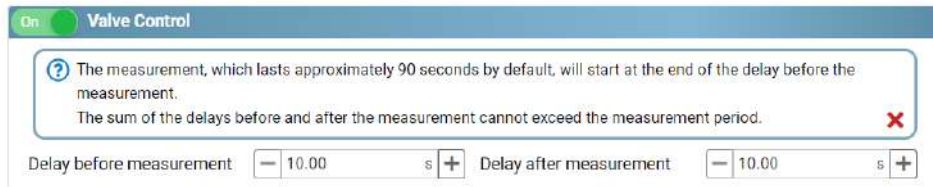

- Set the valve opening and closing delay before and after the measurement.

Set a threshold

- Select a **Threshold parameter** :
 - **Chlorine**
 - **Temperature** if recording is enabled.
 - **PH** if recording is enabled.
 - **ORP** if recording is enabled.
 - **Conductivity** if recording is enabled.
 - **Motor RPM recording** if recording is enabled.
- Select a **Criterion** for the threshold to be activated:
 - **Go below a level**: measured level falls below the set threshold.
 - **Go above a level**: measured level exceeds the set threshold
 - **On rise of at least**: the value between two measurements rises above the set threshold.
 - **On lowering of at least**: the value between two measurements falls below the set threshold.
 - **On high and low threshold**: The measured level exceeds the upper threshold or falls below the lower threshold.

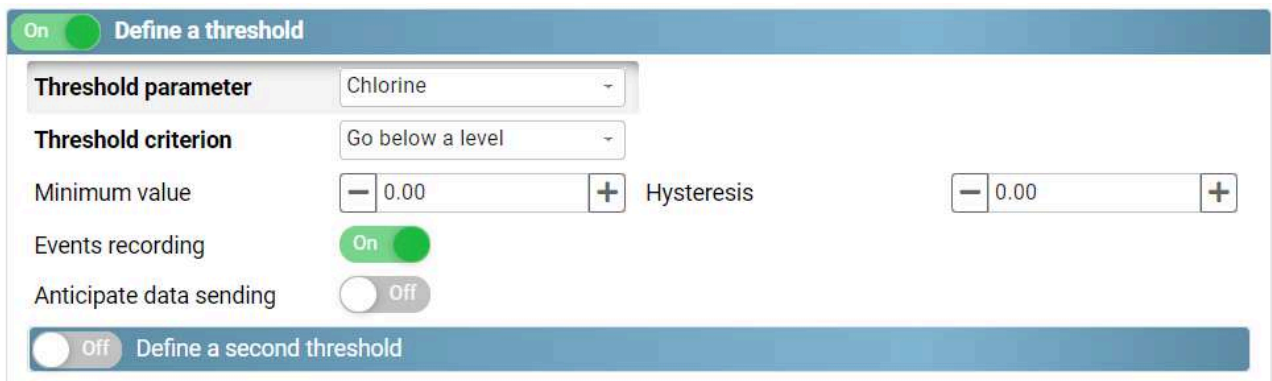

Events recording : binary threshold crossing status (0 or 1) **Anticipate data sending** : If enabled, data transmission is forced when the threshold is exceeded.

Fifo Memory (Advanced Setting)

By default, when the logger memory is full, data are deleted in chronological order of recording, from oldest to newest.

- Click  to display advanced settings.
- If Fifo memory is disabled, change the maximum number of timestamps for the main memory (used for sending data via Internet) and the auxiliary memory (used for sending data via SMS) if necessary.

Maximum records
SMS Maximum records

Configuration overview

To view the configuration summary:

- Click on [SEE OVERVIEW](#) to display a summary of the configuration.

Based on the selected settings, the remaining recording time before the memory is full is displayed, along with an average number of text messages sent per day.

Chlorine sensor Halogen MP5-A 

Measurement every **6 mins**
 Sensor **MP5** : Recording of **Chlorine + temperature + pH + ORP (Redox) + conductivity + motor RPM**
Chlorine threshold according to the criterion : **Go below a level 0**, with **recording of events**
 Valve **opens 10 s** before the measurement and **closes 10 s** after the measurement
 Recording will last for about 4 days 4 hrs / Send around 2.4 SMS each day

[EDIT](#)

Table of correspondences (Data ID / Channel / files)

Da-tald	Channel	Data displayed	Units	Data Description	Data files
0	2	State	.	First threshold event	*_eventhalo.bin
0	3	State	-	Second threshold event	*_eventhalo1.bin
2	0	Debug (positive integer value)	-	Motor speed (RPM)	*_halo.bin
3	7	Debug (signed integer value)	mAh	Internal battery current consumption	*_diag.bin
4	0	Debug (Real value)	-	Chlorine measurement (Res. 0.001 ppm)	*_halo.bin
6	0	Voltage	V	Instantaneous internal battery voltage (Res. 0.05 V)	*_diag.bin
6	1	Voltage	V	Minimum internal battery voltage reached (Res. 0.05 V)	*_diag.bin
6	2	Voltage	V	Instantaneous external battery voltage (Res. 0.05 V)	*_extvolt.bin, *_extbat.bin
12	0	Measure temperature	°C	Sensor temperature measurement (Res. 0.1°C)	*_halo.bin

Da- tald	Channel	Data displayed	Units	Data Description	Data files
17	0	GSM signal Power	dBm	GSM signal power	*_diag.bin
19	0	Date	-	POSIX time	Asynchronous data
26	0	Conductivity	$\mu\text{S/cm}$	Conductivity measurement	*_halo.bin
30	0	pH	-	pH measurement	*_halo.bin
31	0	Redox	mV	ORP (redox) measurement	*_halo.bin

9.6.2. Turbidity measurement using the LowTus probe

Principle

The LowTuS turbidimeter is an online water turbidity measuring device comprising an optical system and related electronic components.

The measuring principle is based on measuring the scattering of infrared light at 90° (ISO 7027) and enables continuous monitoring of turbidity in low measuring ranges.

Configuration



Prerequisites: In Avelour, the Wiji connection to the logger must be established, see [Connecting to the logger](#).

- Click  to add a measurement configuration and select "LowTus turbidity measure".

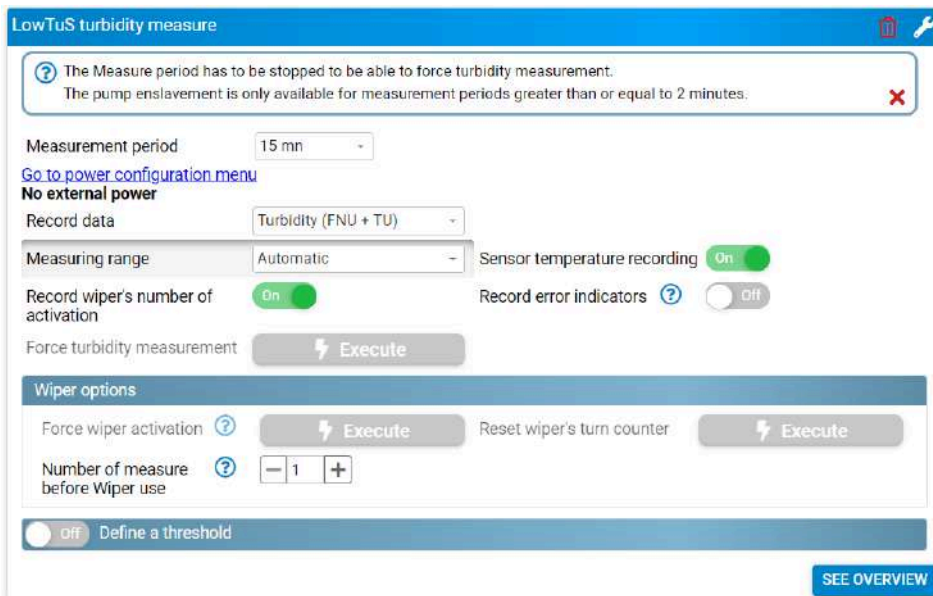

The probe only works with an external power supply.

The measurement period has to be stopped to be able to force turbidity measurement.

The pump enslavement is only available for measurement periods greater than or equal to 2 minutes.

Recorded data

- Select the type of data to be recorded : **FNU / TU** ou **FNU + TU**

Information on measurement Error Indicators

5 indicators can be recorded:

- Voie 10 : Optical noise level is too high
- Voie 11 : Number of cleaning cycles is reached
- Voie 12 : Engine current is high
- Voie 13 : Measurement impossible
- Voie 14 : Cleaning impossible

Pump enslavement (advanced settings + expert mode)



The measurement occurred at the end of pumping to ensure fulfillment of the sensor's chamber.
 The measurement date will be rounded to the minute preceding the end date of pumping.
 The sensor measurement period is included in the pumping start date.



- **Force pump activation and turbidity measurement:** Activates the pump for the set time (45 seconds above)

Wiper options (LowTus premium only)

Regular cleaning of the sensor is necessary to remove deposits that could affect measurements. Automatic cleaning, in the LowTuS Premium version, optimizes the cleaning frequency.



The wiper activates a few seconds before the measurement is taken so as not to interfere with it.
 Forcing the broom through during measurement can distort the results.

- Click on  to display the advanced settings for adjusting the sensor and measurement heating times if necessary.



Number of measurements before sweeping: between 1 and 4 max.

Set a threshold

- Select a **Theshold parameter** :
 - Turbidity FNU
 - Turbidity TU
 - Temperature
 - Wiper's turn counter

- Select a **Criterion** for the threshold to be activated:
 - **Go below a level:** measured level falls below the set threshold.
 - **Go above a level:** measured level exceeds the set threshold
 - **On rise of at least:** the value between two measurements rises above the set threshold.
 - **On lowering of at least:** the value between two measurements falls below the set threshold.
 - **On high and low threshold:** The measured level exceeds the upper threshold or falls below the lower threshold.

Events recording : binary threshold crossing status (0 or 1) **Anticipate data sending** : If enabled, data transmission is forced when the threshold is exceeded.

Fifo Memory (Advanced Setting)

By default, when the logger memory is full, data are deleted in chronological order of recording, from oldest to newest.

- Click to display advanced settings.
- If Fifo memory is disabled, change the maximum number of timestamps for the main memory (used for sending data via Internet) and the auxiliary memory (used for sending data via SMS) if necessary.

Maximum records SMS Maximum records

Résumé de la configuration

To view the configuration summary:

- Click on [SEE OVERVIEW](#) to display a summary of the configuration.

Based on the selected settings, the remaining recording time before the memory is full is displayed, along with an average number of text messages sent per day.

Table of correspondences (Data ID / Channel / files)

Data ID	Channel	Data displayed	Units	Data Description	Data files
0	2	State	.	First threshold event	*_eventhalo.bin
0	3	State	-	Second threshold event	*_eventhalo1.bin
2	0	Debug (positive integer value)	-	Motor speed (RPM)	*_halo.bin
3	7	Debug (signed integer value)	mAh	Internal battery current consumption	*_diag.bin
4	0	Debug (Real value)	-	Chlorine measurement (Res. 0.001 ppm)	*_halo.bin
6	0	Voltage	V	Instantaneous internal battery voltage (Res. 0.05 V)	*_diag.bin
6	1	Voltage	V	Minimum internal battery voltage reached (Res. 0.05 V)	*_diag.bin
6	2	Voltage	V	Instantaneous external battery voltage (Res. 0.05 V)	*_extvolt.bin, *_extbat.bin
12	0	Measure temperature	°C	Sensor temperature measurement (Res. 0.1°C)	*_halo.bin
17	0	GSM signal Power	dBm	GSM signal power	*_diag.bin
19	0	Date	-	POSIX time	Asynchronous data
26	0	Conductivity	µS/cm	Conductivity measurement	*_halo.bin
30	0	pH	-	pH measurement	*_halo.bin
31	0	Redox	mV	ORP (redox) measurement	*_halo.bin

9.6.3. Conductivity measurement via B&C sensor

Principle

The B&C sensor is an inductive conductivity measurement sensor. An electric current is passed through an emitting coil to induce a magnetic field in the liquid. The ions present in the liquid are then passed through by a current. This is measured at a receiver coil.

For more information, the B&C sensor data sheet is available on the Ijinus website: www.ijinus.fr

Settings



Prerequisite: In Avelour, the Wiji connection with the logger must be established, see [Connecting to the logger](#).

- Click on  to add a measurement setting and select "B&C sensor".

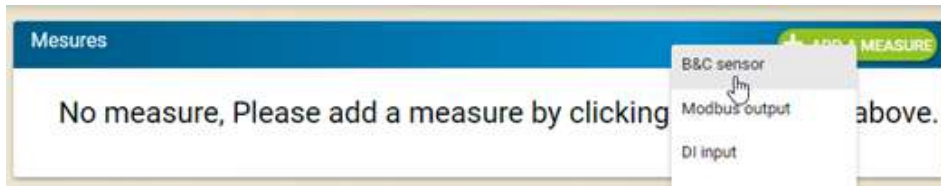

Measurement parameters using a B&C sensor

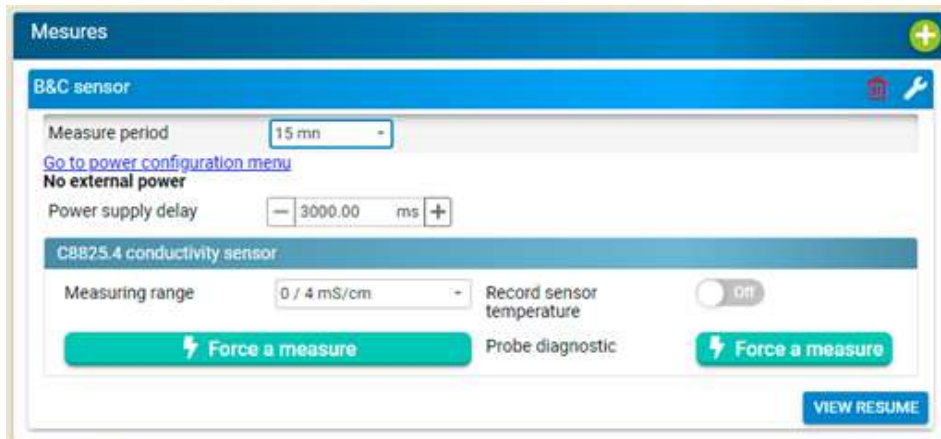

Measurement period

- Select the time between each measurement. In the above example, a measurement will be done every 15 minutes.

Power supply

An external sensor can be powered directly from the logger's internal battery. In this case, no special settings are required.

An external battery or mains supply (7-30V) can also be used.

- If an external power supply (battery or mains) is connected to the logger, refer to paragraph [Using an external battery](#)

For the B&C sensor, the possible voltage range is from 9 V minimum to 36 V maximum.

By default, the power supply delay is set to 3000 ms (3 seconds), which corresponds to the time required for the B&C conductivity probe.

Measuring range

Two different ranges are available: 0 – 4 mS/cm or 0 – 200 mS/cm.

- Choose the range according to the expected conductivity values.

Temperature

- Activate  **record sensor temperature** if necessary.

Checking measurement values

- Click on the left button  to display conductivity and temperature values.

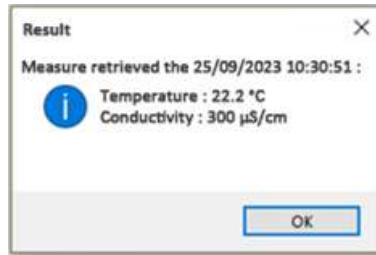

- Click on the right button  to display the recording configuration.

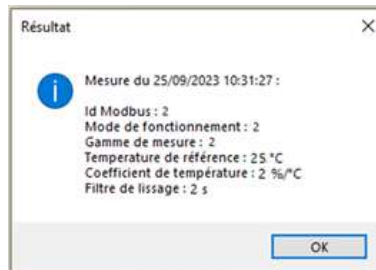

Looping memory Fifo (Advanced parameter)

By default, when the logger's memory is full, data is deleted in chronological order of recording, from the oldest to the most recent.

- If the looping memory is deactivated, set the maximum number of records for the main memory (used for FTP data transmission) and the auxiliary memory (used for SMS data transmission).

Maximum records

SMS Maximum records

Configuration summary

- Click on the "View resume" button to display the summary of the recording configuration.

Depending on the settings selected, the time remaining before the memory is full is given as well as an average of the number of sms sent per day.

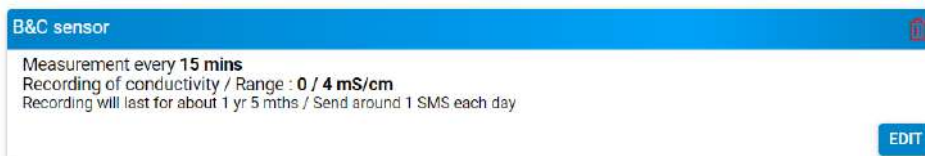

9.6.4. Measurement using the Modbus protocol : Slave mode

Principle

The Modbus protocol can be used to link the logger to a PLC in order to send measured data. In this case, the logger is in "Modbus slave" mode. This option is not available if the Modbus connection is used in slave mode only ("Modbus flowmeter"). This is because the logger has only one Modbus connection, which can be used either as a Modbus master or as a Modbus slave, but it is not possible to use both connections at the same time.



As Modbus communication is based on a notion of requests and responses, it is essential that the logger remains permanently switched on in Modbus slave mode, and consequently the use of an external power supply is necessary. (See [Using an external battery](#) or [Using a mains power supply](#).)

Settings



Prerequisite: In Avelour, the Wiji connection with the logger must be established, see [Connecting to the logger](#).

- Click on the  button to add a configuration measurement and select "Modbus output".



It is essential that these parameters coincide perfectly with the ones expected by the PLC connected to the logger.

Modbus output

Modbus configuration

Slave address	- 1 +	Mode	RTU -
Baudrate	19200 -	Data bits	8 -
Parity	Aucun -	Stop bits	1 -

Data registers

?
Registers table

[More informations here](#)
X

Type of application Industry / farming -

VIEW RESUME

Viewing data logs

A document can be displayed by clicking on the "More information here" link. This document, called "Modbus Tables", describes the address, offset, size and encoding (integer, inverted integer, etc.) for each item of data measured by an Ijinus logger.

Depending on the type of application chosen from the drop-down menu shown below, the table applied (and therefore the data encoding) will not be the same. It is therefore essential to use the correct register table to be able to send the desired measurements to the PLC via the Modbus protocol.

Configuration summary

- Click on the "View resume" button to display the summary of the recording configuration.

Depending on the settings selected, the remaining recording time before the memory is full is given as well as an average of the number of sms sent per day.

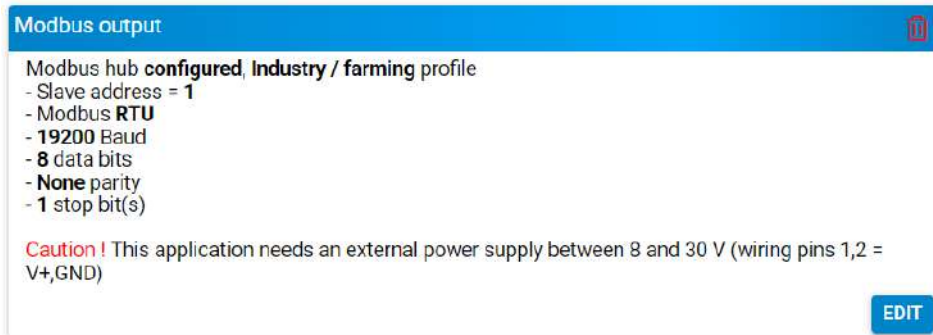

9.6.5. Measurement via 4 digital inputs

Principle

This measurement configuration allows data to be recorded via the recorder's 4 digital inputs. Each Contact/Counter 1-100 input detects the closing of a contact on one of the recorder's digital inputs and then records it with a timestamp of the status changes.

Configuration



When using the measurement configuration on **4 digital inputs** combined with the 4-20 mA input, do not set a measurement period in 4-20 mA below 1 minute.



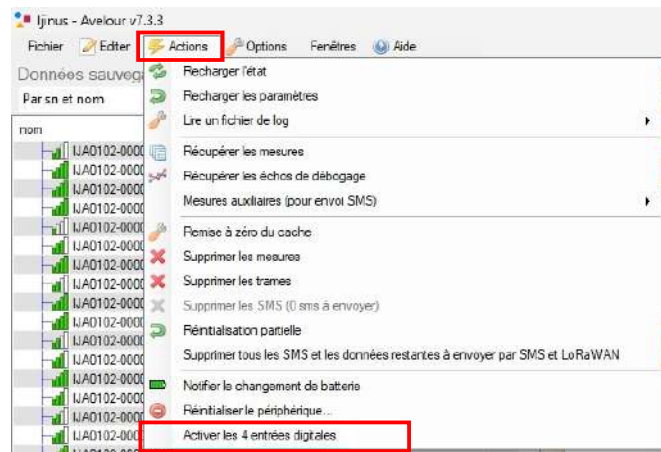

Prerequisite: In Avelour, the Wiji connection with the recorder must be established, see [Connecting to the logger](#).

- Click on  to add a measurement configuration and select **4 Digital inputs**.
- If the measurement does not appear in the list :
 - In the menu **Actions**, click on **Activer les 4 entrées digitales**.

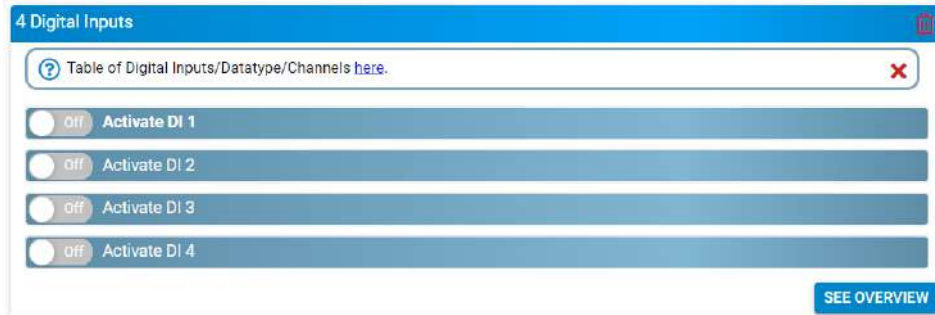



Configuring a contact input (ToR)

- Select as operating mode: **Contact**
- Click on the button  to display contact state.
- Sélectionner le mode de fonctionnement du contact "Normalement fermée" ou "Normalement ouvert".
- Select the operating mode of the contact: "Normally closed" or "Normally open."
- Activate  if necessary, **periodic measurement of the contact status** and select the frequency. By default, only each state change will be recorded.



Actions on state change

- Activate  Actions on state change option provides access to options for anticipating data transmission and open-drain output.

Anticipated data transmission

Activate Open-drain output

- Activer  la sortie Open-drain permet de paramétrer un mode de la sortie **Contact (ToR)** ou **Pulses**.

Output settings in pulse mode: Number of pulses from 1 to 10, duration of high and low states, and repetition

Configuring an input for pulses counting

- Select **Counter** as choice of Opain-drain mode.

- Click on the button  « **Reset counter** » to reset the pulse counter to 0.

Index pulses

- Activate **Index pulsess** option allows the pulses sent by the flow meter to be converted into a volume and therefore a flow rate.
- Enter the **weight** of each pulse, as set in the flow meter.
- Enter the **initial index** corresponding to the initial state before starting the measurement.
- Activate **infinite index recording** to record the cumulative total of the counted indexes.
- Select **Unit of the index** : mm, m³, Weight (Ton) ou Voltage (Watt).
- If init is Volume (m³), activate **Averaged flowrate recording** if necessary.

Flow meter configured to send 1 pulse each time a volume of 0.01 m³ has been measured.

Hourly flow calculation

- Activate calculating the hourly flow rate to display the parameters for recording periodic volumes.
- Activate le **Hourly night flowt** et enter the desired period and the type of calculation to be recorded.

Proportional volume enslaving

- Set the **volume** (m3) for enslaving, **pulse duration**, and **delay between two pulses**.

Actions on threshold

- Select the threshold **type** and **value** :

- On **pulses**.
- On **convert** if **indexation** is activated .
- Sur le **Hourly flow** si le **calcul** is activated .
- Sur le **Hourly maximum night flow** if **calcul** is activated .



Anticipated data sending



Open-drain output in active state

- Activate the open-drain output allows you to configure the output mode. : **Contact** ou **Pulses**.

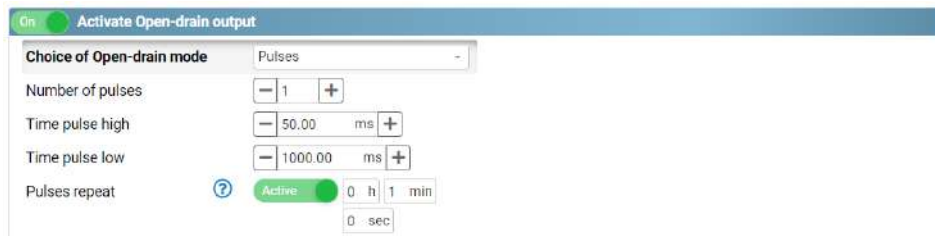

Pulse mode output settings: Number of pulses from 1 to 10, duration of high and low pulse time, and repetition (between 30 seconds and 12 hours)

Looping memory Fifo (Advanced parameter)

By default, when the logger's memory is full, data is deleted in chronological order of recording, from the oldest to the most recent.

- If the looping memory is deactivated, enter the maximum number of timestamps for the main memory (used for FTP transmission) and the auxiliary one (used for SMS data transmission).

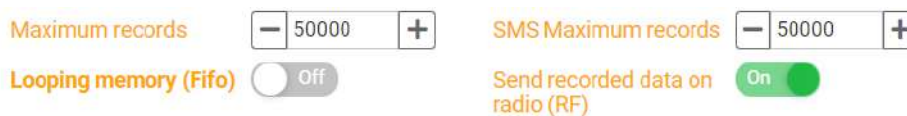

Table of correspondences for Entries / data types / channels

The table below shows the correspondence between the type of data recorded (volume, flow rate, pressure, etc.) and the number coded by the Ijinus logger (datatype) for the two DI meters. As several pieces of data of the same type may be recorded, a channel number is also added to the datatype.

DI n°1

Mode	Data display	Units	Data Description	Datald	Chan-nel	Data Files
Counter	Counter	-	DI1 counter value for the counting period of time	22	0	*_4di-histocnt.bin
Counter	Counter [1]	-	DI1 infinite pulses counter	22	1	*_4di-cnt.bin
Counter	Counter [60]	-	Time (hour) corresponding to the minimum night hourly flow rate for DI1	22	60	*_4di-nightflow0.bin
Counter	Counter [61]	-	Time (hour) corresponding to the maximum night hourly flow rate for DI1	22	61	*_4di-nightflow0.bin
Counter	Counter [124]	-	Number of enslave pulses generated for DI1	22	124	*_4di-sampler0.bin
Counter	Flow rate [10]	m ³ /s	DI1 average flow rate	34	10	*_4di-cnt.bin
Counter	Debug(Real value)/Material height/Volume/Weight/Wattage	-/mm/m ³ /kg/W	DI1 converted value	4/15/39 /42/43	0	*_4di-histocnt.bin
Counter	Debug(Real value)/Material height/Volume/Weight/Wattage [5]	-/mm/m ³ /kg/W	DI1 Total converted value	4/15/39 /42/43	5	*_4di-cnt.bin
Contact	State	-	DI1 Change of state, when occurring	0	0	*_4di-event-di1.bin
Counter	State [10]	-	Threshold status on DI1 change (alert validation)	0	10	*_4di-t-event-di1.bin
Counter	Volume [40]	m ³	DI1 recording of 24h flow	39	40	*_4di-dailyflow0.bin
Counter	Volume [50]	m ³	DI1 recording of hourly flow	39	50	*_4di-hourly-flow0.bin
Counter	Volume [60]	m ³	DI1 minimum night hourly flow	39	60	*_4di-nightflow0.bin
Counter	Volume [61]	m ³	DI1 maximum night hourly flow	39	61	*_4di-nightflow0.bin
Counter	Volume [62]	m ³	DI1 average night hourly flow	39	62	*_4di-nightflow0.bin
All	Debug (signed integer value) [7]	-	Battery gauge value	3	7	*_diag.bin
All	Percentage	%	Percentage of remaining battery	53	0	*_diag.bin

Mode	Data display	Units	Data Description	DataId	Chan- nel	Data Files
All	GSM signal Power	dBm	GSM signal Power	17	0	*_diag.bin
All	Voltage	V	Instantaneous battery voltage (± 0.05 V)	6	0	*_diag.bin
All	Voltage [1]	V	Minimum battery voltage reached (± 0.05 V)	6	1	*_diag.bin

DI n°2

Mode	Data display	Units	Data Description	DataId	Chan- nel	Data Files
Counter	Counter [2]	-	DI2 counter value for the counting period of time	22	2	*_4di-histocnt.bin
Counter	Counter [3]	-	DI2 infinite pulses counter	22	3	*_4di-cnt.bin
Counter	Counter [70]	-	Time (hour) corresponding to the minimum night hourly flow rate for DI2	22	70	*_4di-nightflow1.bin
Counter	Counter [71]	-	Time (hour) corresponding to the maximum night hourly flow rate for DI2	22	71	*_4di-nightflow1.bin
Counter	Counter [124]	-	Number of enslave pulses generated for DI2	22	124	*_4di-sampler1.bin
Counter	Flow rate [11]	m ³ /s	DI2 average flow rate	34	11	*_4di-cnt.bin
Counter	Debug(Real value)/Material height/Volume/Weight/Wattage [1]	-/mm/m ³ /kg/W	DI2 converted value	4/15/39 /42/43	1	*_4di-histocnt.bin
Counter	Debug(Real value)/Material height/Volume/Weight/Wattage [6]	-/mm/m ³ /kg/W	DI2 Total converted value	4/15/39 /42/43	6	*_4di-cnt.bin
Contact	State [1]	-	DI2 Change of state, when occurring	0	1	*_4di-event-di2.bin
Counter	State [11]	-	Threshold status on DI2 change (alert validation)	0	11	*_4di-t-event-di2.bin
Counter	Volume [41]	m ³	DI2 recording of 24h flow	39	41	*_4di-dailyflow1.bin
Counter	Volume [51]	m ³	DI2 recording of hourly flow	39	51	*_4di-hourly-flow1.bin
Counter	Volume [70]	m ³	DI2 minimum night hourly flow	39	70	*_4di-nightflow1.bin
Counter	Volume [71]	m ³	DI2 maximum night hourly flow	39	71	*_4di-nightflow1.bin
Counter	Volume [72]	m ³	DI2 average night hourly flow	39	72	*_4di-nightflow1.bin
All	Debug (signed integer value) [7]	-	Battery gauge value	3	7	*_diag.bin
All	Percentage	%	Percentage of remaining battery	53	0	*_diag.bin
All	GSM signal Power	dBm	GSM signal Power	17	0	*_diag.bin
All	Voltage	V	Instantaneous battery voltage (±0.05 V)	6	0	*_diag.bin

Mode	Data display	Units	Data Description	DataId	Chan- nel	Data Files
All	Voltage [1]	V	Minimum battery voltage reached (± 0.05 V)	6	1	*_diag.bin

DI n°3

Mode	Data display	Units	Data Description	DataId	Chan- nel	Data Files
Counter	Counter [4]	-	DI3 counter value for the counting period of time	22	4	*_4di-histocnt.bin
Counter	Counter [5]	-	DI3 infinite pulses counter	22	5	*_4di-cnt.bin
Counter	Counter [80]	-	Time (hour) corresponding to the minimum night hourly flow rate for DI3	22	80	*_4di-nightflow2.bin
Counter	Counter [81]	-	Time (hour) corresponding to the maximum night hourly flow rate for DI3	22	81	*_4di-nightflow2.bin
Counter	Counter [124]	-	Number of enslave pulses generated for DI3	22	124	*_4di-sampler2.bin
Counter	Flow rate [12]	m ³ /s	DI3 average flow rate	34	12	*_4di-cnt.bin
Counter	Debug(Real value)/Material height/Volume/Weight/Wattage [2]	-/mm/m ³ /kg/W	DI3 converted value	4/15/39 /42/43	2	*_4di-histocnt.bin
Counter	Debug(Real value)/Material height/Volume/Weight/Wattage [7]	-/mm/m ³ /kg/W	DI3 Total converted value	4/15/39 /42/43	7	*_4di-cnt.bin
Contact	State [2]	-	DI3 Change of state, when occurring	0	2	*_4di-event-di3.bin
Counter	State [12]	-	Threshold status on DI3 change (alert validation)	0	12	*_4di-t-event-di3.bin
Counter	Volume [42]	m ³	DI3 recording of 24h flow	39	42	*_4di-dailyflow2.bin
Counter	Volume [52]	m ³	DI3 recording of hourly flow	39	52	*_4di-hourly-flow2.bin
Counter	Volume [80]	m ³	DI3 minimum night hourly flow	39	80	*_4di-nightflow2.bin
Counter	Volume [81]	m ³	DI3 maximum night hourly flow	39	81	*_4di-nightflow2.bin
Counter	Volume [82]	m ³	DI3 average night hourly flow	39	82	*_4di-nightflow2.bin
All	Debug (signed integer value) [7]	-	Battery gauge value	3	7	*_diag.bin
All	Percentage	%	Percentage of remaining battery	53	0	*_diag.bin
All	GSM signal Power	dBm	GSM signal Power	17	0	*_diag.bin
All	Voltage	V	Instantaneous battery voltage (±0.05 V)	6	0	*_diag.bin

Mode	Data display	Units	Data Description	DataId	Chan- nel	Data Files
All	Voltage [1]	V	Minimum battery voltage reached (± 0.05 V)	6	1	*_diag.bin

DI n°4

Mode	Data display	Units	Data Description	Datald	Chan nel	Data Files
Counter	Counter [6]	-	DI4 counter value for the counting period of time	22	6	*_4di-histocnt.bin
Counter	Counter [7]	-	DI4 infinite pulses counter	22	7	*_4di-cnt.bin
Counter	Counter [90]	-	Time (hour) corresponding to the minimum night hourly flow rate for DI4	22	90	*_4di-nightflow3.bin
Counter	Counter [91]	-	Time (hour) corresponding to the maximum night hourly flow rate for DI4	22	91	*_4di-nightflow3.bin
Counter	Counter [124]	-	Number of enslave pulses generated for DI4	22	124	*_4di-sampler3.bin
Counter	Flow rate [13]	m ³ /s	DI4 average flow rate	34	13	*_4di-cnt.bin
Counter	Debug(Real value)/Material height/Volume/Weight/Wattage [3]	-/mm/m3/kg/W	DI4 converted value	4/15/39 /42/43	3	*_4di-histocnt.bin
Counter	Debug(Real value)/Material height/Volume/Weight/Wattage [8]	-/mm/m3/kg/W	DI4 Total converted value	4/15/39 /42/43	8	*_4di-cnt.bin
Contact	State [3]	-	DI4 Change of state, when occurring	0	3	*_4di-event-di4.bin
Counter	State [13]	-	Threshold status on DI4 change (alert validation)	0	13	*_4di-t-event-di4.bin
Counter	Volume [43]	m ³	DI4 recording of 24h flow	39	43	*_4di-dailyflow3.bin
Counter	Volume [53]	m ³	DI4 recording of hourly flow	39	53	*_4di-hourlyflow3.bin
Counter	Volume [90]	m ³	DI4 minimum night hourly flow	39	90	*_4di-nightflow3.bin
Counter	Volume [91]	m ³	DI4 maximum night hourly flow	39	91	*_4di-nightflow3.bin
Counter	Volume [92]	m ³	DI4 average night hourly flow	39	92	*_4di-nightflow3.bin
All	Debug (signed integer value) [7]	-	Battery gauge value	3	7	*_diag.bin
All	Percentage	%	Percentage of remaining battery	53	0	*_diag.bin
All	GSM signal Power	dBm	GSM signal Power	17	0	*_diag.bin
All	Voltage	V	Instantaneous battery voltage (±0.05 V)	6	0	*_diag.bin
All	Voltage [1]	V	Minimum battery voltage reached (±0.05 V)	6	1	*_diag.bin

Résumé de la configuration

Pour visualiser le résumé de la configuration :

- Cliquer sur [SEE OVERVIEW](#) pour afficher un résumé de la configuration

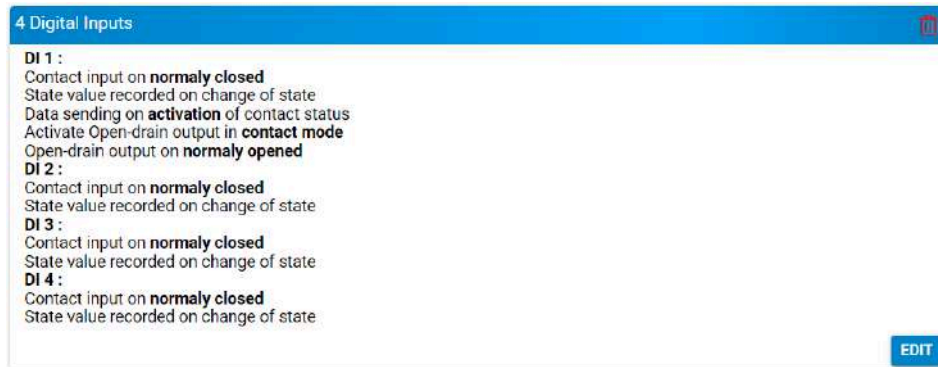

9.6.6. Modbus flow meter

Principle

The "Modbus flowmeter" measurement configuration enables data to be recorded using a flowmeter via Modbus communication, slave mode.

Flowmeter wiring



For correct operation of the flowmeter in MODBUS mode, you need to connect the ground wire. (See paragraph [???](#))

Configuration



Prerequisites: In Avelour, the Wiji connection to the logger must be established, see [Connecting to the logger](#).

- Click  to add a measurement configuration and select "Modbus Flowmeter".

- Select the **Recording period** corresponding to the time between each recording (every 15 minutes for example).
- Select the type of **flow meter** connected to the logger.



List of selectable flowmeters

- Activate if necessary recording of **volume, flow, pressure, temperature, battery capacity** And **direction** parameters.

MODBUS parameter

ABB - AQUAMASTER4

Baudrate : 19200, Bit number : 8, Parity : Even, Stop bit : 1

For wiring, refer to the paragraph [???](#)

ARAD - OCTAVE

Baudrate : 9600, Bit number : 8, Parity : Even, Stop bit : 1

For wiring, refer to the paragraph [la section intitulée « Octave »](#)

ENLESS+HAUSER - PROMAG W800

Baudrate : 9600, Bit number : 8, Parity : Even, Stop bit : 1

For wiring, refer to the paragraph [la section intitulée « Octave »](#)

FUJI ELECTRIC - M5000

Baudrate : 9600, Bit number : 8, Parity : Even, Stop bit : 1

For wiring, refer to the paragraph [_M5000](#)

KROHNE - WATERFLUX 3070

Baudrate : 9600, Bit number : 8, Parity : Even, Stop bit : 1

For wiring, refer to the paragraph [_3070](#)

SIEMENS - MAG 8000

Baudrate : 19200, Bit number : 8, Parity : Even, Stop bit : 1

For wiring, refer to the paragraph [_MAG8000](#)

Modbus slave ID (Advanced parameter)

To enter the Modbus slave ID:

- Click  to display advanced settings.

ID esclave ModBus



Flow calculation

If an hourly flow is activated then it is possible to calculate this hourly volume.

- Enter start and end times.
- Activate if necessary the type of calculation recorded: an **average**, a **minimum** flow rate and/or a **maximum** flow rate.



Check sensor operation

- Click  to view measured values.
 -> Connection to the device is initiated and a new window displays the measured values.

Fifo memory

By default, when the logger's memory is full, data is deleted in chronological order of recording, from oldest to most recent.

- If Fifo memory is disabled, define a maximum number of timestamps.

Maximum records SMS Maximum records

Configuration summary

To view the configuration summary:

- Click on [SEE OVERVIEW](#) to display a summary of the configuration.



Table of datatype correspondences

This file contains, for each brand of flow meter, the correspondence between the type of data recorded (volume, flow rate, pressure, etc.) and the number encoded by the Ijinus logger (datatype). As several identical types of data can be recorded, a channel number is also added to the datatype.

MAG 8000

Displayed Data	DatalD	Channel	Unités	Description	Data Files
Modbus register	21	20	-	Fault status	*_mag8000.bin
Modbus register	21	21	-	Configuration	*_mag8000.bin
Velocity	24	20	mm/s	Velocity	*_mag8000.bin
Flow rate	34	20	m ³ /s	Flow rate	*_mag8000.bin
Volume	39	20	m ³	Forward volume 1	*_mag8000.bin
Volume	39	21	m ³	Reverse volume 2	*_mag8000.bin
Volume	39	22	m ³	Forward volume 2	*_mag8000.bin
Volume	39	24	m ³	Total volume 1	*_mag8000.bin

Debug (signed integer value)	3	20	m ³	Forward volume 1 (integer m ³)	*_mag8000.bin
Debug (signed integer value)	3	21	m ³	Reverse volume 1 (integer m ³)	*_mag8000.bin
Debug (signed integer value)	3	22	m ³	Forward volume 2 (integer m ³)	*_mag8000.bin
Debug (signed integer value)	3	24	m ³	Total volume 1 (integer m ³)	*_mag8000.bin
Debug (positive integer value)	2	22	%	Flowmeter battery charge state	*_mag8000.bin
Counter	22	26	-	Hour of minimum night flow rate	*_min-fm.bin
Counter	22	27	-	Hour of maximal night flow rate	*_max-fm.bin
Volume	39	25	m ³	Hourly volume	*_hourly-flow-fm.bin
Volume	39	26	m ³	Minimum night flow rate	*_min-fm.bin
Volume	39	27	m ³	Maximum night flow rate	*_max-fm.bin
Volume	39	28	m ³	Average flow rate	*_moy-fm.bin
Volume	39	30	m ³	24-hour volume	*_daily-flow-fm.bin
Volume	39	31	m ³	Weekly volume	*_weekly-flow-fm.bin
Volume	39	32	m ³	Monthly volume	*_monthly-flow-fm.bin
State	0	20	-	Threshold state change	*_thres-event-fm.bin
Debug (signed integer value)	3	7	mAh	Internal battery current capacity consumption	*_diag.bin
GSM signal Power	17	0	dBm	GSM signal power	*_diag.bin
Voltage	6	0	V	Instantaneous battery voltage (Res. 0.05 V)	*_diag.bin
Voltage	6	1	V	Minimum battery voltage reached (Res. 0.05 V)	*_diag.bin

Waterflux 3070

Displayed Data	DataID	Channel	Unités	Description	Data Files
Debug (positive integer value)	2	20	-	Flow direction	*_waterflux.bin

Debug (positive integer value)	2	21	-	Alarms	*_waterflux.bin
Debug (Real value)	4	20	Ah	Remaining flow-meter battery capacity	*_waterflux.bin
Temperature	12	20	°C	Liquide temperature (Res. 0.1 °C)	*_waterflux.bin
Velocity	24	20	mm/s	Velocity	*_waterflux.bin
Flow rate	34	20	m ³ /s	Flow rate	*_waterflux.bin
Pressure	37	20	bar	Liquid pressure	*_waterflux.bin
Volume	39	20	m ³	Forward volume	*_waterflux.bin
Volume	39	21	m ³	Reverse volume	*_waterflux.bin
Volume	39	24	m ³	Total volume	*_waterflux.bin
Counter	22	26	-	Hour of minimum night flow rate	*_min-fm.bin
Counter	22	27	-	Hour of maximal night flow rate	*_max-fm.bin
Volume	39	25	m ³	Hourly volume	*_hourly-flow-fm.bin
Volume	39	26	m ³	Minimum night flow rate	*_min-fm.bin
Volume	39	27	m ³	Maximum night flow rate	*_max-fm.bin
Volume	39	28	m ³	Average flow rate	*_moy-fm.bin
Volume	39	30	m ³	24-hour volume	*_daily-flow-fm.bin
Volume	39	31	m ³	Weekly volume	*_weekly-flow-fm.bin
Volume	39	32	m ³	Monthly volume	*_monthly-flow-fm.bin
State	0	20	-	Threshold state change	*_thres-event-fm.bin
Debug (signed integer value)	3	7	mAh	Internal battery current capacity consumption	*_diag.bin
GSM signal Power	17	0	dBm	GSM signal power	*_diag.bin
Voltage	6	0	V	Instantaneous battery voltage (Res. 0.05 V)	*_diag.bin
Voltage	6	1	V	Minimum battery voltage reached (Res. 0.05 V)	*_diag.bin

M5000

Displayed Data	DataID	Channel	Unités	Description	Data Files
Modbus register	21	20	-	Fault	*_m5000.bin
Modbus register	21	21	-	Flow direction	*_m5000.bin
Velocity	24	20	mm/s	Velocity	*_m5000.bin
Flow rate	34	20	m ³ /s	Flow rate	*_m5000.bin
Volume	39	20	m ³	Forward volume 1	*_m5000.bin
Volume	39	21	m ³	Reverse volume 1	*_m5000.bin
Volume	39	22	m ³	Forward volume 2	*_m5000.bin
Volume	39	23	m ³	Reverse volume 2	*_m5000.bin
Volume	39	24	m ³	Total volume	*_m5000.bin
Counter	22	26	-	Hour of minimum night flow rate	*_min-fm.bin
Counter	22	27	-	Hour of maximal night flow rate	*_max-fm.bin
Volume	39	25	m ³	Hourly volume	*_hourly-flow-fm.bin
Volume	39	26	m ³	Minimum night flow rate	*_min-fm.bin
Volume	39	27	m ³	Maximum night flow rate	*_max-fm.bin
Volume	39	28	m ³	Average flow rate	*_moy-fm.bin
Volume	39	30	m ³	24-hour volume	*_daily-flow-fm.bin
Volume	39	31	m ³	Weekly volume	*_weekly-flow-fm.bin
Volume	39	32	m ³	Monthly volume	*_monthly-flow-fm.bin
State	0	20	-	Threshold state change	*_thres-event-fm.bin
Debug (signed integer value)	3	7	mAh	Internal battery current capacity consumption	*_diag.bin
GSM signal Power	17	0	dBm	GSM signal power	*_diag.bin
Voltage	6	0	V	Instantaneous battery voltage (Res. 0.05 V)	*_diag.bin
Voltage	6	1	V	Minimum battery voltage reached (Res. 0.05 V)	*_diag.bin

PROMAG w 800

Displayed Data	DataID	Channel	Unités	Description	Data Files
----------------	--------	---------	--------	-------------	------------

Debug (positive integer value)	2	20	%	Flowmeter battery charge state	*_promag.bin
Debug (positive integer value)	2	21	days	Estimated flowmeter battery life-time	*_promag.bin
Velocity	24	20	mm/s	Velocity	*_promag.bin
Conductivity	26	20	μS/cm	Conductivity	*_promag.bin
Flow rate	34	20	m ³ /s	Flow rate	*_promag.bin
Volume	39	20	m ³	Forward volume	*_promag.bin
Volume	39	21	m ³	Reverse volume	*_promag.bin
Volume	39	24	m ³	Total volume	*_promag.bin
Counter	22	26	-	Hour of minimum night flow rate	*_min-fm.bin
Counter	22	27	-	Hour of maximal night flow rate	*_max-fm.bin
Volume	39	25	m ³	Hourly volume	*_hourly-flow-fm.bin
Volume	39	26	m ³	Minimum night flow rate	*_min-fm.bin
Volume	39	27	m ³	Maximum night flow rate	*_max-fm.bin
Volume	39	28	m ³	Average flow rate	*_moy-fm.bin
Volume	39	30	m ³	24-hour volume	*_daily-flow-fm.bin
Volume	39	31	m ³	Weekly volume	*_weekly-flow-fm.bin
Volume	39	32	m ³	Monthly volume	*_monthly-flow-fm.bin
State	0	20	-	Threshold state change	*_thres-event-fm.bin
Debug (signed integer value)	3	7	mAh	Internal battery current capacity consumption	*_diag.bin
GSM signal Power	17	0	dBm	GSM signal power	*_diag.bin
Voltage	6	0	V	Instantaneous battery voltage (Res. 0.05 V)	*_diag.bin
Voltage	6	1	V	Minimum battery voltage reached (Res. 0.05 V)	*_diag.bin

Octave

Displayed Data	DataID	Channel	Unités	Description	Data Files
----------------	--------	---------	--------	-------------	------------

Debug (positive integer value)	2	20	-	Flow direction	*_octave.bin
Temperature	12	20	°C	Liquid temperature (Res. 0.1 °C)	*_octave.bin
Modbus Register	21	20	-	Alarms	*_octave.bin
Flow rate	34	20	m ³ /s	Flow rate	*_octave.bin
Volume	39	20	m ³	Reverse volume 1	*_octave.bin
Volume	39	21	m ³	Forward volume 2	*_octave.bin
Volume	39	24	m ³	Total volume	*_octave.bin
Counter	22	26	-	Hour of minimum night flow rate	*_min-fm.bin
Counter	22	27	-	Hour of maximal night flow rate	*_max-fm.bin
Volume	39	25	m ³	Hourly volume	*_hourly-flow-fm.bin
Volume	39	26	m ³	Minimum night flow rate	*_min-fm.bin
Volume	39	27	m ³	Maximum night flow rate	*_max-fm.bin
Volume	39	28	m ³	Average flow rate	*_moy-fm.bin
Volume	39	30	m ³	24-hour volume	*_daily-flow-fm.bin
Volume	39	31	m ³	Weekly volume	*_weekly-flow-fm.bin
Volume	39	32	m ³	Monthly volume	*_monthly-flow-fm.bin
State	0	20	-	Threshold state change	*_thres-event-fm.bin
Debug (signed integer value)	3	7	mAh	Internal battery current capacity consumption	*_diag.bin
GSM signal Power	17	0	dBm	GSM signal power	*_diag.bin
Voltage	6	0	V	Instantaneous battery voltage (Res. 0.05 V)	*_diag.bin
Voltage	6	1	V	Minimum battery voltage reached (Res. 0.05 V)	*_diag.bin

Aquamaster

Displayed Data	DataID	Channel	Unités	Description	Data Files
Modbus register	21	20	-	Alarms	*_aqua.bin
Velocity	24	20	mm/s	Velocity	*_aqua.bin
Flow rate	34	20	m ³ /s	Flow rate	*_aqua.bin

Pressure	37	20	bar	Liquid pressure	*_aqua.bin
Volume	39	20	m ³	Forward volume	*_aqua.bin
Volume	39	21	m ³	Reverse volume	*_aqua.bin
Volume	39	24	m ³	Total volume	*_aqua.bin
Counter	22	26	-	Hour of minimum night flow rate	*_min-fm.bin
Counter	22	27	-	Hour of maximal night flow rate	*_max-fm.bin
Volume	39	25	m ³	Hourly volume	*_hourly-flow-fm.bin
Volume	39	26	m ³	Minimum night flow rate	*_min-fm.bin
Volume	39	27	m ³	Maximum night flow rate	*_max-fm.bin
Volume	39	28	m ³	Average flow rate	*_moy-fm.bin
Volume	39	30	m ³	24-hour volume	*_daily-flow-fm.bin
Volume	39	31	m ³	Weekly volume	*_weekly-flow-fm.bin
Volume	39	32	m ³	Monthly volume	*_monthly-flow-fm.bin
State	0	20	-	Threshold state change	*_thres-event-fm.bin
Debug (signed integer value)	3	7	mAh	Internal battery current capacity consumption	*_diag.bin
GSM signal Power	17	0	dBm	GSM signal power	*_diag.bin
Voltage	6	0	V	Instantaneous battery voltage (Res. 0.05 V)	*_diag.bin
Voltage	6	1	V	Minimum battery voltage reached (Res. 0.05 V)	*_diag.bin

9.6.7. Modbus master

Principle

The modbus master configuration is a tool for performing read, write and delay operations directly in modbus 485 communication.

Configuration



The configuration of the recorder in modbus master mode is intended for expert users to configure products directly in modbus 485 communication. It therefore represents an alternative to the products/tools directly integrated by Ijinus. However, it is important to know the prerequisites for using this tool.



Prerequisites: In Avelour, the Wiji connection to the logger must be established, see [Connecting to the logger](#).

- Click  to add a measurement configuration and select "Modbus master".

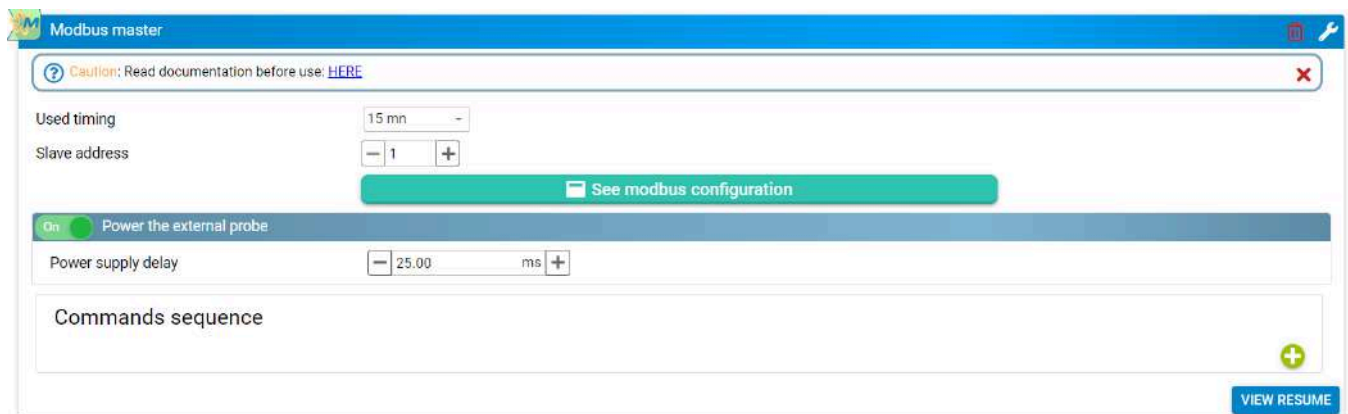

Modbus configuration



It is essential that these parameters match exactly with the product connected in modbus slave.

Modbus configuration			
Mode	RTU	Baudrate	9600
Data bits	8	Parity	Aucun
Stop bits	1	Timeout (Modbus request)	250.00 ms

CLOSE

Default master modbus configuration

Sequence of commands

Read register

Read register commands are limited to 8 maximum.

To add a register reading, click .

Read Modbus register

name	<input type="text" value="Vmax"/>
Address	<input type="text" value="85"/>
Format	<input type="text" value="Unsigned 16 -"/>
Byte order	<input type="text" value="AB -"/>
Function Code	<input type="text" value="Read Holding Registers (0x03) -"/>
Output Type	<input type="text" value="Debug (positive integer value) [2] -"/>
Conversion	
value=	<input type="text" value="1"/> * (x + <input type="text" value="0"/>) + <input type="text" value="0"/>

- Modbus function 0x03 or 0x04
- Format of the data read: Unsigned16, Signed16, Unsigned32, Signed32, Float
- **Byte order** possible depending on the format: AB, BA, ABCD (W1W2), DCBA, CDAB (W2W1), BADC
- **Function** modbus 0x03 or 0x04
- Read value converted to the chosen Ijinus datatype.
- Possible linear conversion of the value: Value = A * (X + B) + C
- Button to test the command in expert mode.

Write to register

Read register commands are limited to 8 maximum.

To add a register entry, click .

Write Modbus register

name	<input type="text" value="STOP"/>
Address	<input type="text" value="65533"/>
Format	<input type="text" value="Unsigned 16 -"/>
Byte order	<input type="text" value="AB -"/>
Function Code	<input type="text" value="Write Single Registers (0x06) -"/>
Value to write (decimal)	<input type="text" value="0"/>

CANCEL

OK

- **Format** of written data: Unsigned16, Signed16, Unsigned32, Signed32, Float
- **Byte order** possible depending on the format: AB, BA, ABCD (W1W2), DCBA, CDAB (W2W1), BADC
- **Function** modbus 0x06 or 0x10
- **Value to write** : Write a constant to the target register

Add a delay

Delay commands are limited to 8 maximum.

- To add a delay between two commands, click  and enter a delay in ms.

Configuration summary

To view the configuration summary:

- Click [SEE OVERVIEW](#) to display a summary of the configuration.

Depending on the selected settings, the remaining recording time before the memory is full is given as well as an average of the number of SMS sent per day.

Modbus master
⌵

Data recording every **15 mins**

Modbus commands : **1 Read / 1 Write**

Slave address : 1 (9600 bps 8 N 1)

Power the external probe (25ms)

Record : Debug (positive integer value)

[EDIT](#)

9.6.8. Measurement using a 4-20 mA signal

Principle

This measurement is used to set the parameters for retrieving data from a sensor connected to a logger via a 4-20 mA signal.

Settings



Prerequisite: In Avelour, the Wiji connection with the logger must be established, see [Connecting to the logger](#).

- Click on the  button to add a measurement and select "4-20mA measure".



Measure period

- Select a value in the list. In the above example, measurement will be done every 15 minutes.

External sensor power supply

By default, the sensor power supply is activated. If the sensor is already powered by an energy source other than the logger, then it must be deactivated.

If the external sensor is powered by the logger, then it is possible to use either the internal battery (within the limit of 5 to 18 V and 1.8 Watt maximum) or to connect an external battery between the logger and the sensor. In this case, the logger must be configured by clicking on the "Go to power management block" link. See [Using an external battery.Power supply configuration](#)

Whether the sensor is powered by the internal battery or via an external battery, it is very important to determine the power supply time. This is the length of time the sensor will be powered by the logger before measuring the 4-20 mA signal emitted by the external sensor.

- If this time is too short, the measured 4-20 mA signal will not be correct and the measured value may be slightly or even extremely different from that actually expected.
- If the power supply time is too long, the measured 4-20 mA signal will be correct but the system autonomy will be reduced due to excessive energy consumption.

It is not possible to specify a power supply duration as this can vary from 25 ms for some piezometric sensors to several tens of seconds for some water level sensors. The default value has been set at 250 ms because this time is used to power the 4-20 mA piezometers sold by Ijinus.



For the inclinometer sold by Ijinus, the minimum power-up time is 500 ms.

First channel 4-20 mA



To set up the BLUE-LP, channel 1 is used for the integrated pressure sensor.

- Select one of the two 4-20mA signal input for **Peripheral**.

4-20 mA signal conversion

If no conversion is set, then only the value of the 4-20 mA signal will be recorded.



- Activate **Conversion** to convert the 4-20 mA signal into a parameter to be chosen from the drop-down menu.
- In the Convert current list, select the desired conversion unit.
- **Value at 4mA**, set the minimum value (usually 0) of the connected sensor.
- **Offset on conversion**: Enter an offset if necessary for the measurement.
- Enter a **Adjustement value** to calibrate the sensor.
- For the **Value at 20mA**, set the full scale value of the connected sensor.

There are two main types of conversion: height conversion and other types of conversion. In fact, height conversion allows flow/volume calculation options, as well as the slaving of a sampling system.



This option is rarely used for drinking water network diagnostics. However, as it is a feature shared with the sanitation range of data loggers, the possibility of converting the 4-20 mA signal into a water level is presented below.

Conversion example

In the example below, the 4-20 mA sensor is a piezometer with a range of 0-10m (10,000 mm).

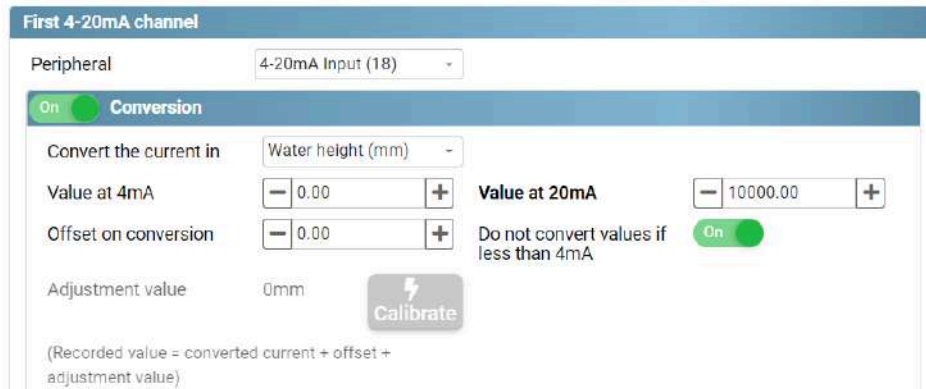

Relation Flowrate / Volume

These options are only available if the 4-20 mA signal is converted to water height.

- Click on the "fill table" button to enter a height/flow table so that the logger can transform the 4-20 mA signal into a height of water and then transform the height of water into a flow rate.



Be careful to respect the units indicated in the table.

- Activate the **volume accumulation** to enable flows to be transformed into volume transited. It is then possible to record a cumulative hourly, daily or monthly volume.
- Activate **record infinite accumulation** if needed.

 Execute button allows to reset the infinite counter.



The screenshot shows a web interface with three main sections:

- Conversion:** Includes fields for 'Water height (mm)', 'Value at 4mA', 'Offset on conversion', and 'Adjustment value'. There are also fields for 'Value at 20mA' and a 'Do not convert values if less than 4mA' checkbox. A 'Calibrate' button is present.
- Flowrate / Volume:** Includes a 'Height/flowrate table (10 lines)' with a 'Fill table' button, a 'Cumulated volume' dropdown set to 'Hourly', and a 'Record infinite accumulation' checkbox. There is also a 'Reset the infinite counter' button and an 'Execute' button.
- Sampler enslaving:** Includes a 'Pulse output peripheral' dropdown set to 'Open-drain Output (15)', a 'Force one pulse' button with a lightning bolt icon, an 'Enslaving condition' dropdown set to 'None', and a 'Volume enslaving' field set to '1.000 m³'.

Sampler slaving

If a height/flow relationship has been specified, then it is possible to send pulses to a sampler connected to a logger.

- Select a **Pulse output peripheral**.
- Click on the  button to test the link between the logger and the sampler. By clicking on this button, the logger sends a pulse to the Open-Drain output, which must be detected by the connected sampler.
- Select an **Enslaving condition**: either on a height of water or on the flow..

If a condition is selected :

- Enter a **Threshold** in mm and a **hysteresis** in mm for this condition. **Hysteresis** parameter define an upper or lower value for which the condition remain true.

Example: In the case of a slaving condition with a height under a low-level of 100 mm and a hysteresis of 5 mm, the salving condition remains active until the height falls below 105 mm.

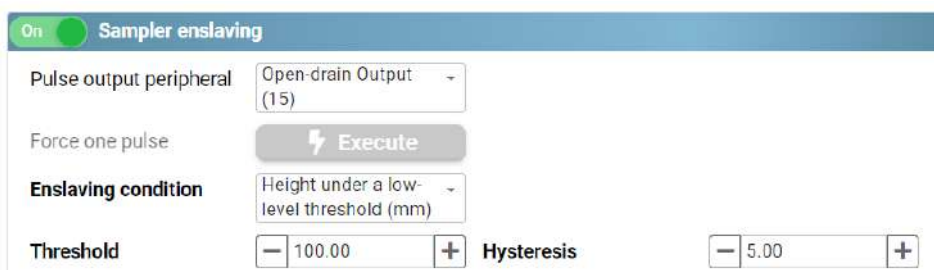

The screenshot shows the 'Sampler enslaving' configuration section with the following settings:

- On** (toggle switch)
- Pulse output peripheral:** Open-drain Output (15)
- Force one pulse:** Execute button (lightning bolt icon)
- Enslaving condition:** Height under a low-level threshold (mm)
- Threshold:** 100.00
- Hysteresis:** 5.00

- Enter a **delay** for this condition, either when pulses are activated or when they are deactivated.



It is possible to receive an SMS alert message when the set threshold is exceeded (See [Sending an alert SMS](#)).

2 slaving criteria are possible:

- **Volume enslaving:** This means that, in the example above, 1 pulse will be sent each time the logger measures 1 m³ of volume transited.

- Time slaving: This means that, as long as the condition is active, 1 pulse will be sent to the sampler at the set frequency. The number and frequency of pulses sent will not be affected by the flow rate measured.



Between two measurements the logger is in standby and therefore cannot send pulses. At the time of measurement, if the logger calculates a transited volume of 5 m³ for example, then 5 pulses will be sent in succession. Similarly, if the pulse sending frequency is set to 1 minute but the 4-20 mA measurement frequency is only 5 minutes, no pulses will be sent between 2 measurements. On the other hand, every time you wake up, and if the slaving condition is still met, 5 pulses will be sent to the sampler every 5 minutes.

Converting current into pressure, temperature, angle, speed or any other unitless variable

For other types of conversion, the options are the same as for the bar conversion shown below.

In the example below, the 4-20 mA sensor is a 0-16 bar range sensor. It is possible to adjust the measurement made to a reference measurement, using the offset on the conversion.

- If necessary, activate the option **do not convert current values if they are less than 4 mA**. The conversion will then be made at the value indicated at 4 mA (in the example below: 0 bar) whether the current is measured at 0 mA, 2 mA or 3.99 mA.

On
Conversion

Convert the current in Pressure (bar) ▾

Value at 4mA - 0.00 + Value at 20mA - 16.00 +

Offset on conversion - 0.00 +

Do not convert values if less than 4mA On

Second 4 - 20 mA channel

It is possible to add a second 4-20 mA sensor to the logger. The options and possibilities are identical to those already presented for the first 4-20 mA sensor.

Set a threshold 1



It is possible to receive an SMS alert message when the set threshold is exceeded (See [Sending an alert SMS](#)).

In this example, the threshold is based on the conversion of channel 1 to "rising edge" for the direction. The delay can also be set for activation and/or deactivation.

- Activate **acceleration** and select a new period to speed up the measurement period,

It is also possible to anticipate the sending of data (if the logger's communication mode allows) on the activation and/or deactivation of the configured threshold.

- Activate the Open-Drain output to close a contact if the threshold is exceeded (normally open operation), or to open the contact if the threshold is exceeded (normally closed).

On ●
Set a threshold 1

Source data Current channel 1 -

Direction Falling edge / Closed contact -

Threshold - 0.00 + Hysteresis - 0.00 +

Delay before activation 0 h 0 min 0 sec Delay before deactivation 0 h 0 min 0 sec

Actions

Acceleration Active ● Stop -

Output activation Active ● Open-drain Output (15) - **Polarity** Normally closed -

Set a threshold 2

It is possible to set a second threshold for which neither the measurement acceleration option nor the option to activate the Open-Drain output is available.



It is possible to receive an SMS alert message when the set threshold is exceeded (See [Sending an alert SMS](#)).

Looping memory Fifo (Advanced parameter)

By default, when the logger's memory is full, data is deleted in chronological order of recording, from the oldest to the most recent.

- If the looping memory is deactivated, enter the maximum number of timestamps for the main memory (used for FTP transmission) and the auxiliary one (used for SMS data transmission).

Maximum records - 50000 +

Looping memory (Fifo) Off

SMS Maximum records - 50000 +

Send recorded data on radio (RF) On

Configuration summary

To view the configuration summary:

- Click on the "View resume" button to display the summary of the recording configuration.

Depending on the parameters values selected, the remaining recording time before the memory is full is given as well as an average of the number of sms sent per day.

4-20mA measure
✖

4-20mA measure every **15 mins**

First channel : conversion in **Water height (mm)**, (4mA = 0 / 20mA = 10000)
No second channel

Threshold 1: **Current channel 1** on the criteria : **above 0** with an **hysteresis 0** .
- output activation.

Recording will last for about 1 yr 5 mths / Send around 1.9 SMS each day

⚡ Test measure
EDIT

Table of correspondences

Data-tald	Channel	Data displayed	Units	Data Description	Data files
0	0-15	State	-	Threshold event recording - Channel 1	*_event.bin
0	0-15	State	-	Threshold event recording - Channel 2	*_event-2.bin
3	7	Debug (signed integer value)	mAh	Internal battery current consumption	*_diag.bin
4	0	Debug (Real value)	-	Conversion of current into quantity without unit - Channel 1	*_cu.bin
4	1	Debug (Real value)	-	Conversion of current into quantity without unit - Channel 2	*_cu.bin
6	0	Voltage	V	Instantaneous internal battery voltage (Res. 0.05 V)	*_diag.bin
6	1	Voltage	V	Minimum internal battery voltage reached (Res. 0.05 V)	*_diag.bin
6	2	Voltage	V	Instantaneous external battery voltage (Res. 0.05 V)	*_extvolt.bin, *_extbat.bin
10	0	Current	mA	Current signal (Res. 0.01 mA) - Channel 1	*_cu.bin
10	1	Current	mA	Current signal (Res. 0.01 mA) - Channel 2	*_cu.bin
12	0	Measure temperature	°C	Conversion of current into temperature - Channel 1	*_cu.bin
12	1	Measure temperature	°C	Conversion of current into temperature - Channel 2	*_cu.bin
15	0	Material height	mm	Conversion of current into water height - Channel 1	*_cu.bin
15	1	Material height	mm	Conversion of current into water height - Channel 2	*_cu.bin
17	0	GSM signal Power	dBm	GSM signal power	*_diag.bin
19	0	Date	-	POSIX time	Asynchronous data
20	0-15	Overflow	-	Threshold event recording - Channel 1	*_event.bin
20	0-15	Overflow	-	Threshold event recording - Channel 2	*_event-2.bin
24	0	Velocity	mm/s	Conversion of current into velocity - Channel 1	*_cu.bin
24	1	Velocity	mm/s	Conversion of current into velocity - Channel 2	*_cu.bin
34	0	Flow rate	m ³ /s	Flow rate calculation - Channel 1	*_flow1.bin
34	1	Flow rate	m ³ /s	Flow rate calculation - Channel 2	*_flow2.bin

Da-tald	Channel	Data displayed	Units	Data Description	Data files
37	0	Pressure	bar	Conversion of current into pressure - Channel 1	*_cu.bin
37	1	Pressure	bar	Conversion of current into pressure - Channel 2	*_cu.bin
39	0	Volume	m ³	Cumulated volume over the defined period - Channel 1	*_volcount1.bin
39	1	Volume	m ³	Infinite accumulation of volume - Channel 1	*_flow1.bin
39	2	Volume	m ³	Cumulated volume over the defined period - Channel 2	*_volcount2.bin
39	3	Volume	m ³	Infinite accumulation of volume - Channel 2	*_flow2.bin
44	0	Angle	°	Conversion of current into angle - Channel 1	*_cu.bin
44	1	Angle	°	Conversion of current into angle - Channel 2	*_cu.bin

9.7. Configuring the sending data

9.7.1. Technologies used

Different methods of data transmission are possible, such as SMS messages or Internet communication using FTP(s), HTTP(s) or CoAP protocols. For this, several technologies can be used: 2G, 3G, LTE-M, NB-IoT and MQTT(s).

The use of a communication PCB is possible to transmit data over LoRaWAN.



NB-IoT technology does not allow data to be sent by SMS.

A very important factor in data transmission is the quality of the telephone operator's signal at the location where the logger is installed. Depending on how the logger is installed, signal quality may be degraded, for example if the logger is placed in a manhole closed by a metal cover.



The quality of the signal during data transmission has an impact on the logger's battery life. Indeed, the poorer the signal quality, the higher the energy consumption needed for transmission.

9.7.2. Signal quality: Mobile Signal Strength Value

Signal strength (dBm)	Signal quality
+ 49 dBm	Default value that may indicate a network connection problem
- 70 to -80 dBm	Very good quality
- 80 to -90 dBm	Good quality

Signal strength (dBm)	Signal quality
- 90 to -100 dBm	Average quality
- 100 to - 105 dBm	Poor signal quality
+ 113 dBm	No communication possible

9.7.3. Configuring the modem of the communication card



Prerequisites: A SIM card with a “voice” or SMS message package must be inserted into the holder. See paragraph [Inserting a SIM card](#) parameters.

Before being able to send data by SMS or M2M, you must configure the modem on the communication board.

- In the “Data sending” block, click “EDIT”.

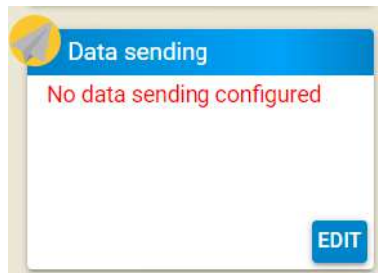

-> The data transmission parameter editing window is displayed.

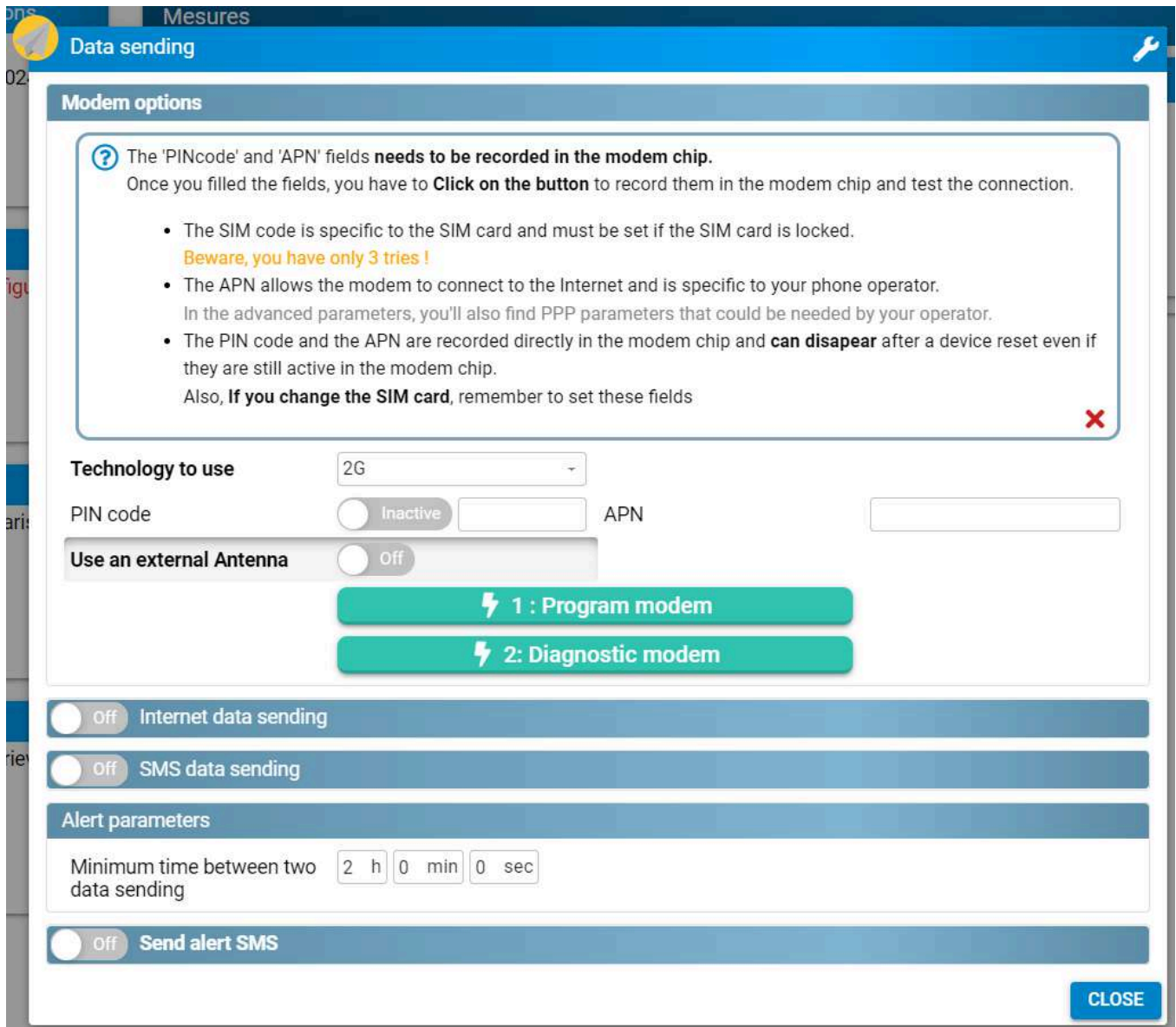

Technology to use

- Choose the technology used.

This could be 2G, 3G, LTE-M, or NB-IoT technology. For 3G, LTE-M and NB-IoT technologies, you can choose an option where 2G technology will be used as a backup if the selected technology is not available.



The selected technology must be compatible with the SIM card inserted in the logger and with the relay antennas located near the logger.

PIN code

- Enter a value in the field if the SIM card is protected by a PIN code.



Only 3 attempts are possible before the SIM card is blocked.

APN

- If the data is sent in M2M (by FTP (S) or CoAP), configure the APN of the SIM card. Hover the mouse over the question mark to display a list of the APN of some telephone operators.
- If a private APN with password is used, click on the icon  at the top right of the application to switch to advanced settings.

-> New options appear including fields, where necessary, to specify the username (PPP User) and the password (PPP Password).

- Activate the parameter to enter values in empty fields.

Technology to use	<input type="text" value="2G"/>	Priority operator 	<input type="checkbox"/> Inactive	<input type="text" value="20801"/>
PIN code	<input type="checkbox"/> Inactive	<input type="text" value="APN"/>		
PPP phone	<input type="checkbox"/> Inactive	PPP user	<input type="checkbox"/> Inactive	<input type="text"/>
PPP password	<input type="checkbox"/> Inactive	Use an external Antenna	<input type="checkbox"/> Off	
⚡ 1 : Program modem				
⚡ 2: Diagnostic modem				
Modem connection timeout	<input type="checkbox"/> Inactive	<input type="text" value="120"/>		

Priority operator (Multi-operator SIM)



This feature requires a firmware update (22.1 or later). Refer to paragraph [Firmware update](#).

This feature can only be used with a multi-operator SIM card.

In the case of a multi-operator SIM card, each time a data transmission occurs, a search for a connection to one of the available networks is launched randomly. If after 60 seconds, the attempt to connect to a network fails due to lack of signal strength, the SIM card then attempts to connect to another available network and therefore consumes electrical power.

To prevent the SIM card from attempting to connect to a network with excessively low signal strength, you can specify a priority operator network by entering its MCC + MDC code. (20820: Bouygues, 20801: Orange, 20810: SFR).

To define the priority operator, preferably the one with the highest signal strength at the measurement point, it is advisable to test the signal strength of all operators to determine which one to use in priority. To do this:

- Apply measurement conditions.
- Activate "Priority operator" and enter the operator code of the network to test. (20820: Bouygues, 20801: Orange, 20810: SFR)
- Click "Program modem".

- Click “Diagnostic Modem” and view the signal strength value. Refer to paragraph [Signal quality: Mobile Signal Strength Value](#) parameters.
- Repeat the procedure for all mobile network operators to determine the optimal operator for the measurement site.

Program modem

When the Modem parameters have been configured:

- Click on the button  “1: Program modem”.



You must click the “1: Program modem” button to send data to the modem; simply saving the configuration does not allow you to configure the modem.



1 : Program modem

-> Programming the modem takes a few minutes. When the configuration is complete, a window opens to indicate the result:



-> If the programming did not occur correctly, a window opens to indicate the problem encountered (SIM card absent, incorrect PIN code, etc.)

- Each time a parameter is modified (e.g. change of technology), click on the “1: Program modem” button.

9.7.4. Check network quality: Modem diagnostics

After setting up the Modem, you need to make sure that a communication network is available.

- Click the button "2: Modem diagnostic".



-> the communication PCB boots up and searches for a mobile network signal. A window opens to display the results

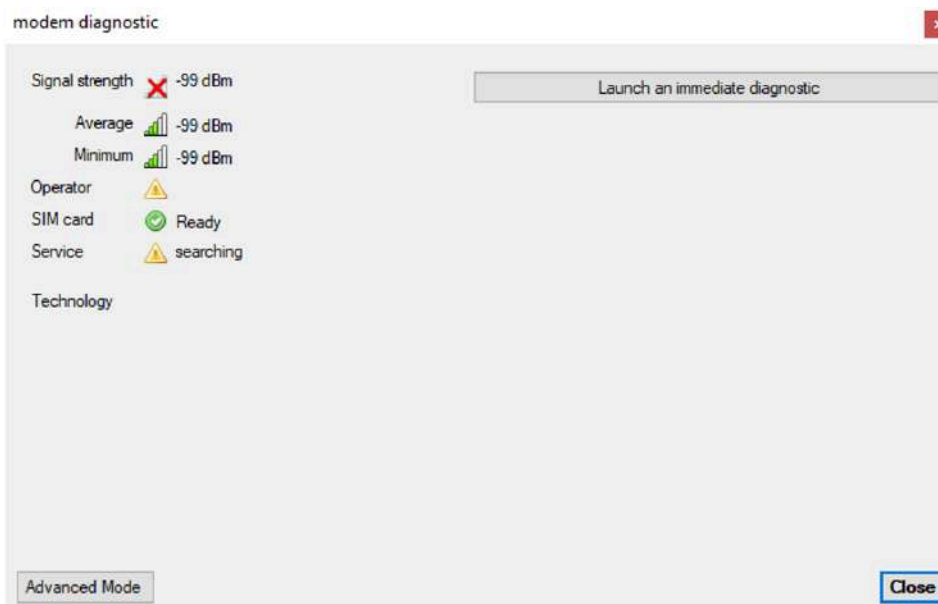

"Modem Status" window -

If the result is as shown above, it means that no signal has been located.

- Click the "Launch an immediate diagnostic" button to give the modem more time to detect a network. In less than a minute, a satisfactory result should appear as indicated below:

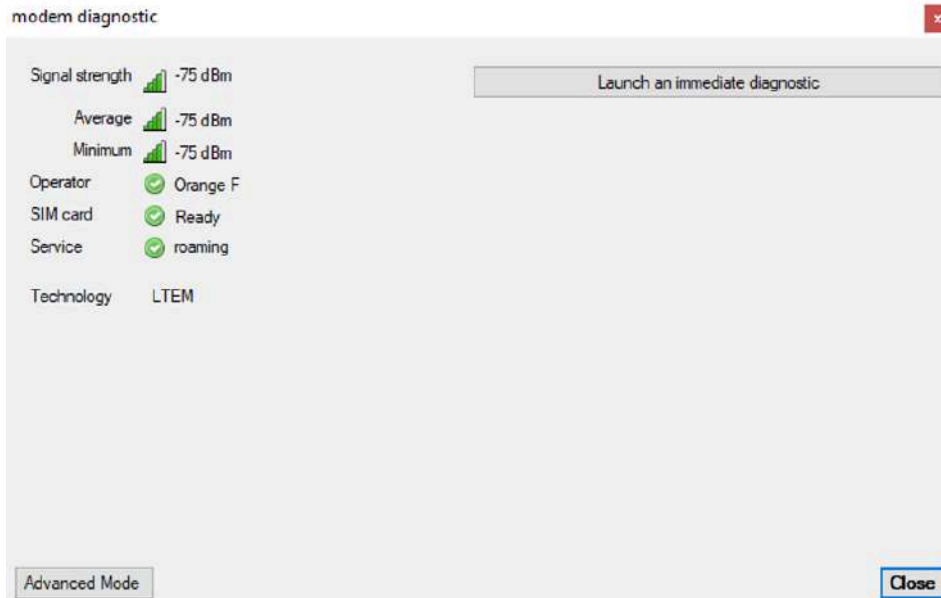

If after 5 minutes of searching the result is not satisfactory, it means that there is a problem with connecting to the network. Several cases are possible:

Problem	Corrective action
No network is available for the selected technology.	<ul style="list-style-type: none"> Select another communication technology if the SIM card allows it, then click on the "1: program modem" button
No network is available for the SIM card operator	<ul style="list-style-type: none"> Use a multi-carrier SIM card or a SIM card from another carrier
No network is available for any technology.	<ul style="list-style-type: none"> Place the external antenna connected to the logger in a location where communication is more favorable. For example, if the antenna was placed in a manhole or facility, move it outside.
SIM card is not activated	<ul style="list-style-type: none"> Check with the SIM card provider that it has been activated.



Pay attention to the scope of validity of the SIM card. Some SIM cards may be limited to certain countries or continents depending on the subscription purchased.

By using the advanced mode, it is possible to perform continuous signal strength measurements over a longer period of time. This option can be used to set the best position of the antenna before drilling a hole in the manhole to offset the antenna from the metal cover.

9.7.5. Data sending in FTP(s)

- Insert a SIM card (with a data package of at least 5 MB per month) into the holder. See paragraph [Setting up a SIM card](#).
- When purchasing a SIM card, ask for the operator's APN and PIN code, if available, as this information will be needed.
- Connect the GSM / GPRS antenna to the connector on top of the logger.
- In Avelour, activate **Data sending via Internet: FTP / CoAP**

- Select the data **transmission cycle**.

By default, the logger is programmed to send data to Ijitrack. In this case, no modification to the existing configuration is required.

- If you do not have an Ijitrack account, please contact our customer service department.



You will be asked to provide the product number on the logger label and the installation address.

- If data is being sent to a server other than Ijitrack, click on the  icon in the top right of the screen to go to advanced settings and display the following parameters:

- If necessary, contact the FTP server administrator to obtain the three parameters required to send data to a server:
 - Server name or IP address: "Server"
 - Name of user accessing the server: "Username"

- Password associated with the user: "Password"
- Click on the  **FTP data transmission test** button to check that data transmission is working correctly.



-> If data is transmitted, the following window appears:

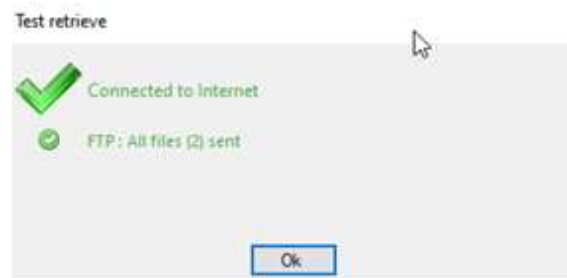

- After a few minutes, check that the data has arrived on the Ijitrack account or on a different Ijitrack server.

9.7.6. Data sending in Http(s)



Requires firmware version later than or equal to 22.04.

Configuration

Under “Internet data sending”,

- Activate **Internet data sending** and select the HTTP protocol,

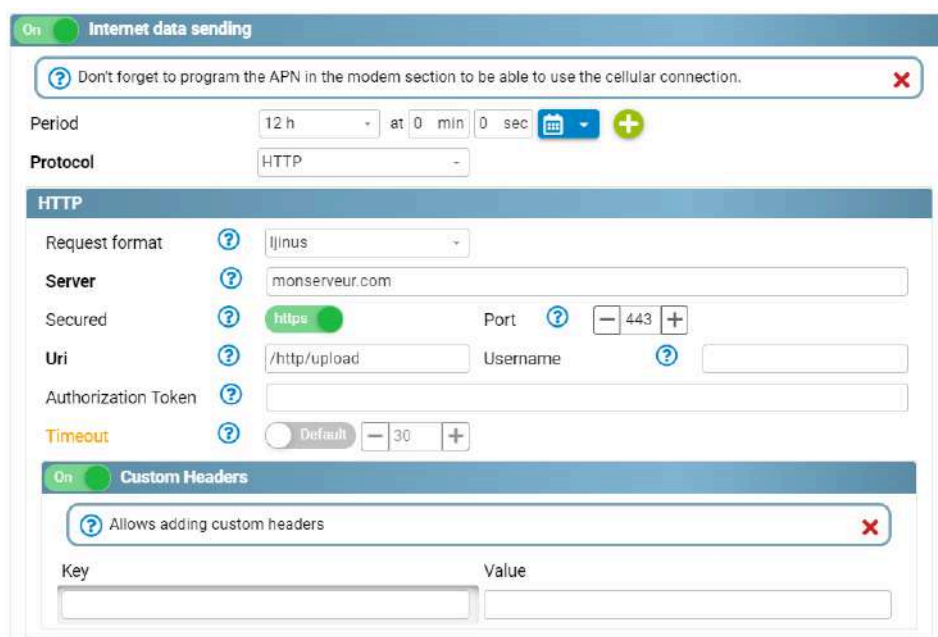

Sending data via HTTPS in ijinus format

- **Request format:** Ijinus, Topkapi, Azure IoT Hub.
 - **Ijinus:** Ijinus is a format that allows interoperability with most systems. It is fairly generic and contains all the information you might need. Moreover, custom values can also be added in the header.
 - **Topkapi:** Specific format for compatibility with Topkapi.
 - **Azure IoT Hub:** Format for compatibility with the Azure platform.
- **Server:** Enter the URL of the target server (without http/https). For ijinus, the server is files.ijitrack.com.
- **Port:** Enter the HTTP listening port on the server side.
- **Secure:** HTTP or HTTPS.
- **Uri :** Enter the url of the http request. Not available for ijinus format with files.ijitrack.com server.
- **User name:** With Ijinus format. If needed. It will be included in the body of the request in the user form. It is useful when sending to Ijinus servers.
- **Authentication token:** Enter the authorization token, if required. Will be included in the request body in the Authorization header.

- **Timeout:** Enter an http request timeout in seconds.
- * **Custom headers*:** With the Ijinus format. Enables custom headers.
 - **Key:** Enter the header key to be added.
 - **Value:** Enter its value.

Ijinus format

Format of the request sent via a **POST** for the Ijinus format.

POST_Request		
Header	Authorization	58d97_32fb3
	<Key0>	<Value0>
	<Key1>	<Value1>
	<Key2>	<Value2>
	<Key3>	<Value3>
form-data body	tz	Europe/Paris
	user	ijinusHTTP
	sn	IJA0102-12345678
	crc32	1234ABCDE
	file	data.bin

URL

The url will be in the form: [http|https]://

In the example above the url will be: https://myserver.com/http/upload.

Request header

- **Authorization:** Authentication token, if required.
- **Key0:** Custom header 0.
- **Key1:** Custom header 1.
- **Key2:** Custom header 2.
- **Key3:** Custom header 3.

Body

The body is in form-data format.

- **tz:** Enter the timezone configured in the sensor.
- **user:** Enter the user (as defined [above](#)).
- **sn:** Enter the sensor serial number.
- **filepath:** Enter the file path and its name into the sensor.
- **crc32:** Enter the CRC32 of the file.

-
- **file:** Enter the file in `application/octet-stream..`

Topkapi format

For TOPKAPI communication:

- Enter the server name or IP address and the Authentication Token provided by TOPKAPI.
- For sensor configuration in TOPKAPI, refer to TOPKAPI documentation.

Azure IoT HUB format

For preformatted transmission to Azure IoT Hub.

The uri is preconfigured in the right format: `/devices/ $id/messages/events?api-version=2021-04-12`

Request header:

Header	
Authorization	58d97-32fb3

The body is in the format "

```
{  
  "payload": "base64:sdip<gs5fsd465ggsgs"  
}
```

9.7.7. Data sending in MQTT(s)

Principle

MQTT is a client-server messaging protocol using the publish/subscribe architecture.

At the heart of MQTT are MQTT brokers and clients. The Broker is an intermediary between senders and recipients. Its role is to distribute messages to the appropriate recipients. Clients post messages to the broker and other clients subscribe to specific topics to receive messages.

Each message includes a topic and customers subscribe to topics that interest them. The broker maintains a list of subscriptions and uses it to deliver messages to the relevant clients.

A broker can also buffer messages for disconnected clients, ensuring reliable message delivery even under unreliable network conditions. To enable this, MQTT supports three different Quality of Service (QoS) levels for message delivery: 0 (at most once), 1 (at least once), and 2 (exactly once) (HiveMQ).

Message format

The format of MQTT messages is json (JavaScript Object Notation).

```

Topic: Ijinus/Logger/IJA0102-00001848/DATA/diag QoS: 0 Retained
{
  "sn": "IJA0102-00001848",
  "tzMinutesOffset": "+120",
  "tzLabel": "CEST",
  "descriptors": [
    {
      "datatype": 6,
      "channel": 0
    },
    {
      "datatype": 6,
      "channel": 1
    },
    {
      "datatype": 3,
      "channel": 7
    },
    {
      "datatype": 17,
      "channel": 0
    }
  ],
  "records": {
    "2025-04-10T11:45:08Z": {"0": 3.45, "1": 3.35, "2": "221", "3": -73}
  }
}
  
```

Activation



The logger must be equipped with a modem board with a SIM card.

- In Avelour, activate **Internet data sending**

- Set a transmission cycle.
- Select the **MQTT** protocol.

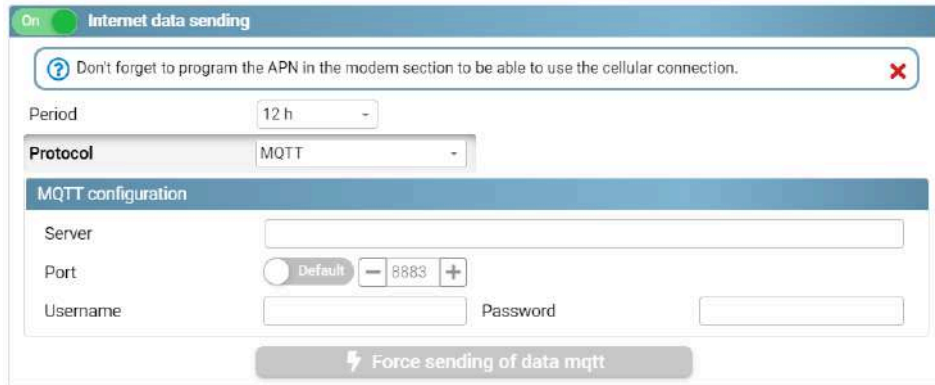

Configuration

- Enter the **Server** identifiers, **Port**, **Username** and **Password**.

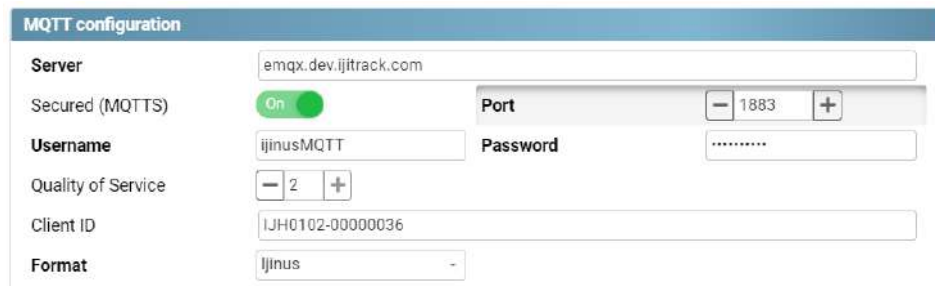

Quality of Service (advanced setting)

The MQTT protocol has a quality of service (or QoS) mechanism, which guarantees the delivery of messages to the client in the event of a failure (e.g., connectivity).

- Click on  to display the advanced setting **Quality of service** and enter a value of 0, 1, or 2.

QoS 0: Lowest quality. The message is only sent once. In the event of a failure, some messages may not be delivered. This quality may be suitable for sending sensor data where occasional data loss would not significantly impact the overall results.

QoS 1: Quality level where messages are confirmed and resent if necessary. This level of quality of service is typically used in situations where message loss is unacceptable, but message duplication is tolerable. This is suitable for sending command messages to devices, where a missed command can lead to serious consequences, but duplicate commands do not.

QoS 2: This level enables "exactly once" delivery, where messages are confirmed and resent until they are received exactly once by the subscriber. Quality of Service level 2 is the highest level of quality of service and is generally used in situations where message loss or duplication is completely unacceptable. With QoS 2, the client and broker use a two-step confirmation process, in which the broker stores the message until it has been received and acknowledged by the subscriber. This level of quality of service is typically used for critical messages such as emergency alerts.

Format Almaviva

In the **Almaviva** format, The option "**Send descriptor**" allows to open a new /DESC channel describing the correspondence between the recorded data tracks and the "Var".

Format Send descriptor

Topic

 For Almaviva format, topic structure will be:

- ljinus/Logger/IJH0102-00000036/HData
- ljinus/Logger/IJH0102-00000036/LOG
- ljinus/Logger/IJH0102-00000036/DESC

Topic Prefix

Topic (advanced setting)

The MQTT messaging model is based on topics and subscriptions. Topics are channels where messages are posted and subscribed to. Topics are hierarchical and can contain multiple levels separated by slashes, like a file path.

- Click on  to display the advanced setting **Topic** and customize the topic format if needed.

Topic

 Topic format will be:

- ljinus/Logger/IJA0102-00000129/DATA/#
- ljinus/Logger/IJA0102-00000129/LOG/#

ClientID GroupID

9.7.8. Advanced internet connection settings

In advanced mode , the following parameters are displayed:

PPP

Attempts to connect Default Timeout to connect Default

SNTP

Sntp server Default

DNS

Alternative DNS server Prioritise the alternative DNS server Off

PPP

PPP : Point to point Protocol -> Internet transmission protocol that enables a connection to be established between two hosts over a point-to-point link.

SNTP

SNTP : Simple network time protocol -> Protocol used to synchronise the clocks of devices on a data network.

- Activate **Snt server** and enter the server address for synchronisation.

Custom DNS server

Alternative DNS server : If necessary, enter the IP address of the custom DNS server to add it to the list contained on the SIM card.

Prioritise the alternative DNS server : Must be enabled to allow priority use of custom DNS.

9.7.9. Certificate management

Generalities

A digital certificate or public key certificate is used primarily to identify and authenticate a natural or legal person, but also to encrypt communications. It can be compared to a digital identity card.

A digital certificate is a data file that associates a publicly known cryptographic key with an organization.

Electronic certificates are verified using a chain of trust. The anchor point of this chain is the *root certification authority*.

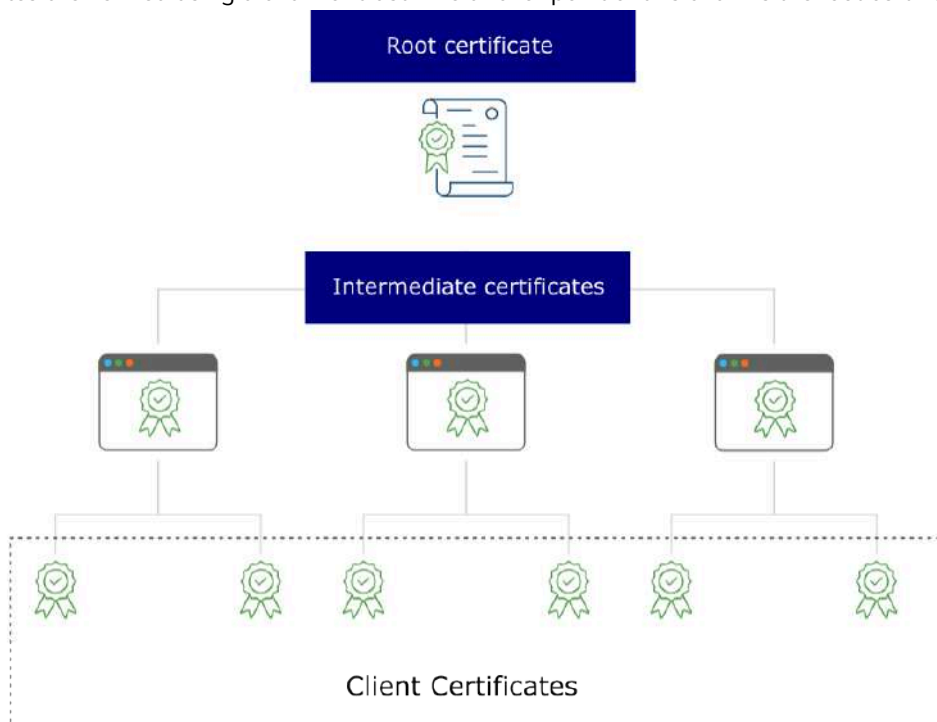

Root certificate

A root certificate, often referred to as a CA certificate, is a digital certificate that serves as the basis for a public key infrastructure (PKI) system. It is issued by a trusted certification authority (CA) and is self-signed, meaning that the CA authenticates itself. Root certificates are stored in a trusted repository known as a root store, which is maintained by browsers and operating systems to authenticate secure connections.

Intermediate certificate

The intermediate certificate serves as a bridge between the root certificate and server certificates, such as TLS certificates for websites. Unlike root certificates, intermediate certificates are not self-signed; they are signed by a root certificate or another intermediate certificate. This structure creates a hierarchy known as a chain of trust.

Managing certificate



The Certificate Management feature button is only visible if the protocol is enabled as secure.

Secured (MQTTS)



General

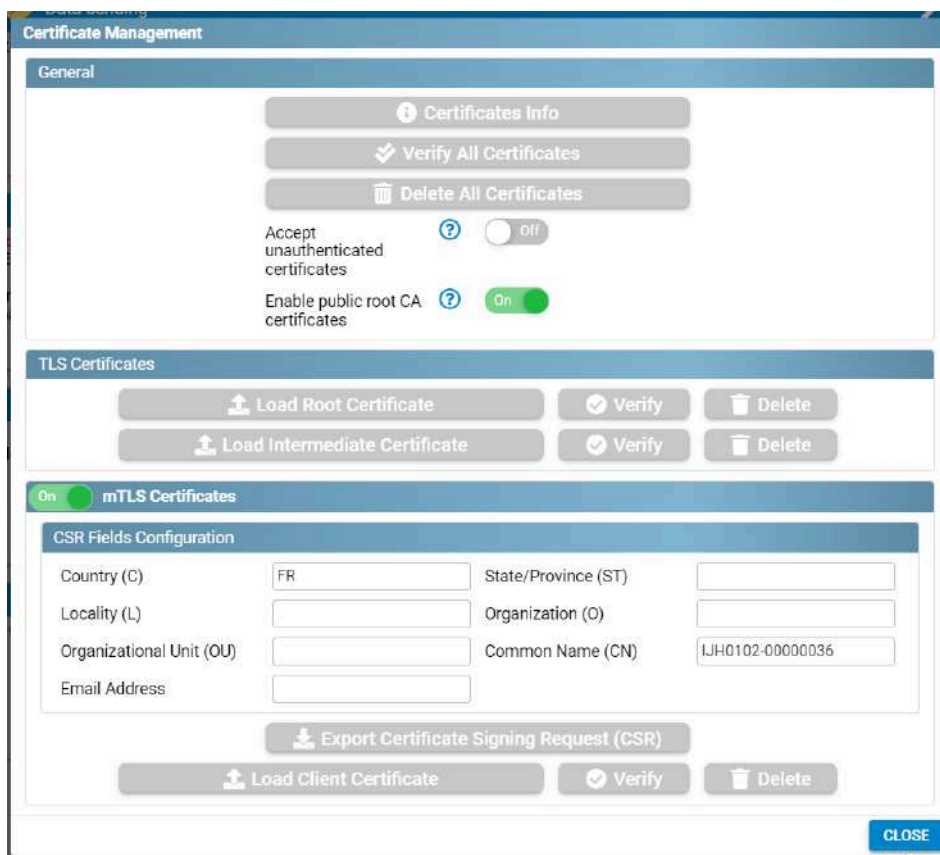

The screenshot shows the 'Certificate Management' interface. It is divided into three main sections:

- General:** Contains buttons for 'Certificates Info', 'Verify All Certificates', and 'Delete All Certificates'. It also has two toggle switches: 'Accept unauthenticated certificates' (set to 'off') and 'Enable public root CA certificates' (set to 'On').
- TLS Certificates:** Contains two rows of buttons. The first row has 'Load Root Certificate', 'Verify', and 'Delete'. The second row has 'Load Intermediate Certificate', 'Verify', and 'Delete'.
- mTLS Certificates:** The 'mTLS Certificates' toggle is 'On'. Below it is the 'CSR Fields Configuration' section with input fields for:

Country (C)	FR	State/Province (ST)	
Locality (L)		Organization (O)	
Organizational Unit (OU)		Common Name (CN)	IJH0102-00000036
Email Address			

 Below the fields are buttons for 'Export Certificate Signing Request (CSR)', 'Load Client Certificate', 'Verify', and 'Delete'.

A 'CLOSE' button is located at the bottom right of the interface.

The **Accept unauthenticated certificates** feature, i.e., certificates that are not signed by a trusted certification authority, can be useful in development and testing environments.

The **Enable Public Root CA Certificates** feature allows you to authorize only private or public certificates.

mTLS certificates

Mutual TLS (mTLS) is an authentication method that ensures secure communication between both parties in a connection. Unlike the traditional TLS method, which only verifies the identity of the server, mTLS authenticates both the client and the server by exchanging and validating digital certificates.

mTLS ensures that the parties at each end of a network connection are who they claim to be by verifying that they both possess the correct private key. The information contained in their respective TLS certificates provides additional verification.

1. The client connects to the server
2. The server presents its TLS certificate
3. The client verifies the server certificate
4. The client presents its TLS certificate
5. The server verifies the client's certificate
6. The server grants access
7. The client and server exchange information via an encrypted TLS connection

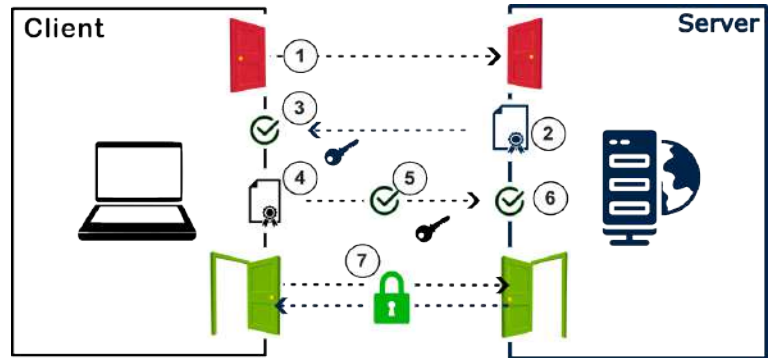

CSR certificate and client certificate

To obtain a client certificate, a certificate signing request (CSR) must be made to a CA in order to obtain a client digital identity certificate.

- Fill in the CSR fields and export the request.
- Upload the client certificate (.pem or .ce)

9.7.10. Data sending via SMS

To configure SMS data transmission:

- Click on "EDIT" in the "Data sending" block.

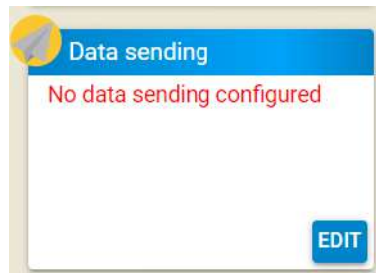

- Activate "SMS data sending".

The **Sending period** corresponds to the frequency at which data are transmitted.

In the example below, transmission occurs every 12 hours:



To check that SMS messages have been sent correctly:

- Enter a phone number in the **Send a test SMS** field indicating the country code (+33 for France).
- Then click on the  **Send a test SMS** button and check that the SMS has arrived on the phone identified.

```
IJA0102-00002088  
Ver : 0129/01-1  
Rev : 21.13 (2023/04/03 - Radar)  
2023/11/10 17:04:04  
Rat: 2G GSM-900  
Oper : Orange  
Rssi : -49 dBm (ext)
```

Example of an SMS received on the recipient's phone

- Enter the **server phone** number to transmit the data.

The **SMS Site ID** is a value that identifies the logger on the server and the supervision system used to display the data.

- If data are sent to the Ijitrack web service, no modification is required.
- If data are sent to another supervision system, contact the person in charge of supervision to define the correct SMS Site ID.

9.7.11. Data sending in LoRaWAN



The configuration of data transmission in LoRaWAN is available from version 7.1.2 of the Avelour software.

A logger equipped with an built-in modem has a unique identifier (DevUID). This identifier is required to configure your LoRaWAN server (LNS: Lora Network Server).

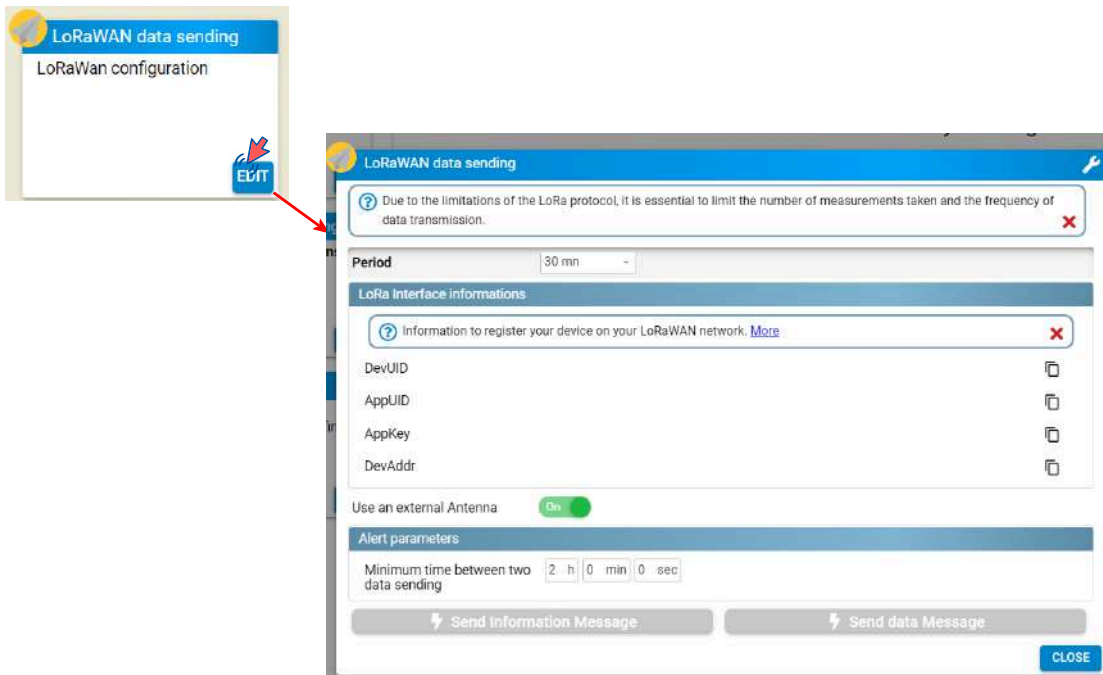

Transmission cycle

- Select the frequency of the data transmission cycle on the LoRaWAN server.

Login information

DevEUI: Identity of the end device (64 bits).

AppEUI: Identity of the application (makes the owner of the end device unique).

AppKey: Key used by the server and the end device to encrypt and decrypt packet data.

DevAddr: Identity of the end device (32 bits).

Test data transmission

- Click “Send information message” to send a message containing diagnostic information
- Click “Send data message” to send a message containing measurement data.

Advanced settings

<p>Downlink Waiting Time </p> <p>Request for acknowledgment </p>	<p><input type="text" value="1000"/> ms <input type="button" value="+"/></p> <p><input type="checkbox"/> Off</p>	<p>Timeout </p> <p>Multiple send </p>	<p><input type="text" value="10000"/> ms <input type="button" value="+"/></p> <p><input type="text" value="1"/> <input type="button" value="+"/></p>
--	--	---	--

Downlink waiting time

Waiting time between the end of message transmission and the start of the LNS downlink frame listening phase (for TTN: 5000 ms)

Timeout

Maximum network connection time (ms).

Request for acknowledgement

For all transmissions, activate the request for acknowledgement from the LNS.



Depending on the platform, this may be a paid option.

Multiple send

If there is no acknowledgement, data can be sent multiple times to increase the reception rate.

Expert mode

Reset period

Modem reset periods to ensure that the modem is working. Forces the modem to disconnect from and reconnect to the network.

Use an external antenna

On: External antenna

Off: Internal antenna

Integration of a logger on Orange Live objects

- Select the "Generic_classA_RX2SF12" profile.
- Copy and paste the identifier (DevEUI) and the keys (AppKey and AppEUI) from the data provided in Avelour.

Interface - LoRa

DevEUI *

Profil *

Options de connectivité Macro-géolocalisation LoRa

Plan de connectivité *

AppEUI *

AppKey *

Integration of a logger on WIOTYS

- Select the “LorawanPrivate” protocol
- Copy and paste the identifier (DevEUI) and the keys (AppKey and AppEUI) from the data provided in Avelour.

PARAMÈTRES

DevEUI *

App Key *

AppEUI *

Type d'activation

Classe

Integration of a logger on THE THINGS

- Select “Enter end device specifics manually”
- Fill in the Frequency plan, LoRaWAN version and Regional Parameters fields as shown below:

Register end device

Does your end device have a LoRaWAN® Device Identification QR Code? Scan it to speed up onboarding.

Scan end device QR code Device registration [help](#)

End device type

Input method

- Select the end device in the LoRaWAN Device Repository
- Enter end device specifics manually

Frequency plan

Europe 863-870 MHz (SF12 for RX2)

LoRaWAN version

LoRaWAN Specification 1.0.2

Regional Parameters version

RP001 Regional Parameters 1.0.2

Show advanced activation, LoRaWAN class and cluster settings

Provisioning information

JoinEUI

..... Confirm

To continue, please enter the JoinEUI of the end device so we can determine onboarding options

- Copy and paste the identifier (DevEUI) and the keys (AppKey (= JoinEUI) and AppEUI) from the data provided in Avelour.

Provisioning information

JoinEUI

70 B3 D5 32 60 01 00 = AppEUI (Avelour)

This end device can be registered on the network

DevEUI

70 B3 D5 32 60 07 29 D8 0/50 used

AppKey

AA 4E 6C 37 85 E3 3A 5E F8 45 31 30 8D CE E8 AC

End device ID

eui-70b3d532600729d8

This value is automatically prefilled using the DevEUI

9.7.12. Configure an alarm

To avoid draining the internal battery too quickly in the event of a programming error, a safety feature can be configured: "alarm parameter". By default, this parameter imposes a minimum duration of 2 hours between two transmissions related to an alert.

- In the "data sending" window,



- Enter a minimum time between two transmissions.

9.7.13. Sending an alert SMS



The server phone number needs to be configured.

The SIM card must allow sending of SMS text messages.

Sending an alert SMS only works if a threshold is exceeded and Anticipate data sending is active.

- Enter a phone number in the "Send alert SMS" window.

-> A second input field appears, allowing you to add another operator and each time a field is filled another field appears.



It is possible to add up to a maximum of 9 phone numbers.



If data is sent using FTP, approximately 3 minutes elapses between the time that the threshold is exceeded and the message is received.

9.8. Sending logger configuration using server (remote configuration)

9.8.1. Principle

To modify the settings of a logger without being connected via radio link (wiji), you need to have specific access to the Ijitrack server.

Remote configuration cannot be performed via SMS. Only the **Internet data sending** option allows you to send data and receive a new configuration file.

In fact, data is no longer sent to the root of the Ijitrack server but to a specific space protected by a username and password that are different from those used for Ijitrack.

These server access settings must be entered into the Avelour software when configuring the radio link recorder.

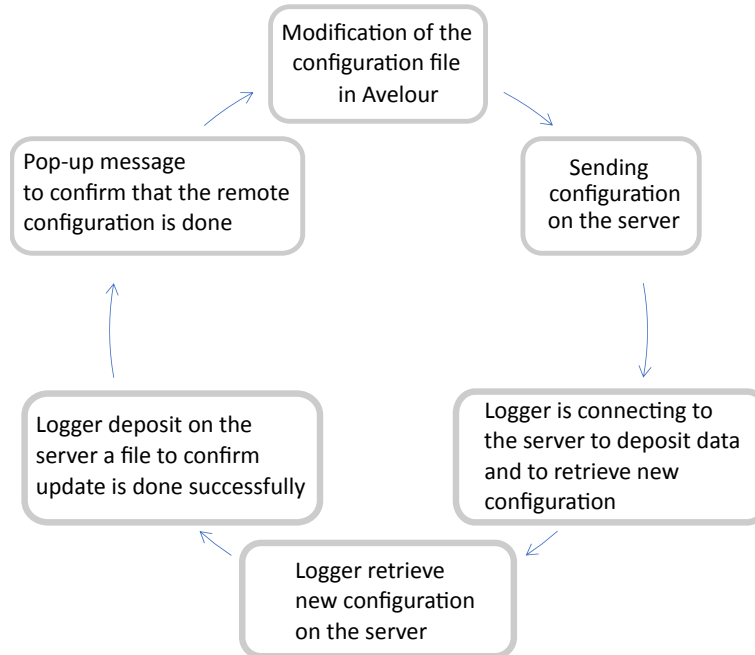

9.8.2. Configuring server access on Avelour

FTP



Contact customer service to unlock the feature that allows you to customize specific access other than Ijitrack.

- In the **Options** menu, click on **Configuration** and go to the **Remote Config** tab.
- Enter the broker name, the username and the password.
- When it's done, click on "Test MQTT" button to check that the connection between Avelour and the MQTT Broker is available.
- If yes, it's possible to modify a setting or a Firmware remotely.
- If not, a modification must be done on written data.

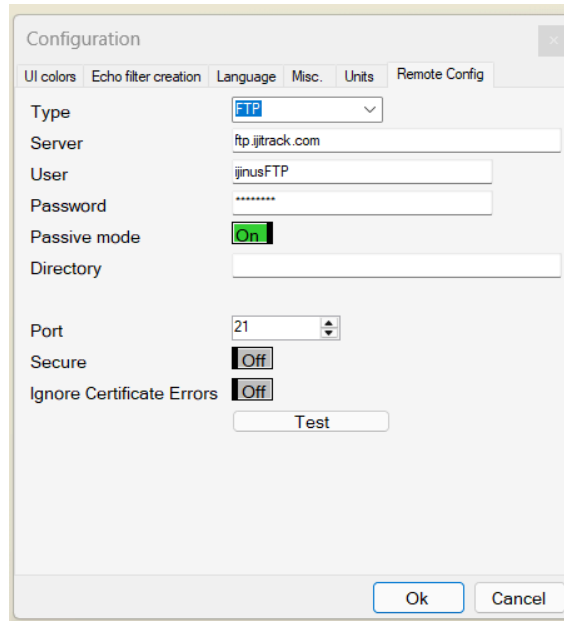

HTTP



Contact customer service to unlock the feature that allows you to customize specific access other than Ijitrack.

- In the **Options** menu, click on **Configuration** and go to the **Remote Config** tab.
- Enter the access parameters (Server, user, API key, port) exactly as they were entered in the data transmission configuration.
- When it's done, click on "Test HTTP" button to check that the connection between Avelour and the MQTT Broker is available.
- If mTLS is enabled, refer to the paragraph [Certificate management](#).

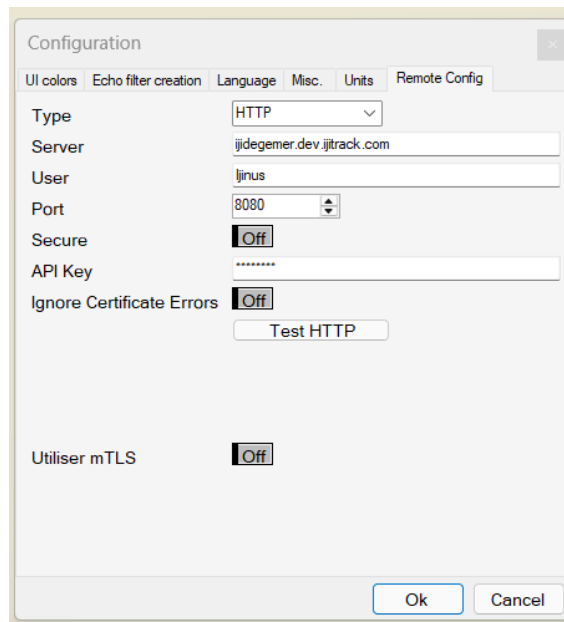

Configuration

UI colors Echo filter creation Language Misc. Units Remote Config

Type

Server

User

Port

Secure

API Key

Ignore Certificate Errors

Utiliser mTLS

MQTT



Contact customer service to unlock the feature that allows you to customize specific access other than Ijitrack.

- In the **Options** menu, click on **Configuration** and go to the **Remote Config** tab.
- Enter the access parameters (Server, user, API key, port) exactly as they were entered in the data transmission configuration.
- When it's done, click on "Test MQTT" button to check that the connection between Avelour and the MQTT Broker is available.
- If mTLS is enabled, refer to the paragraph [Certificate management](#).

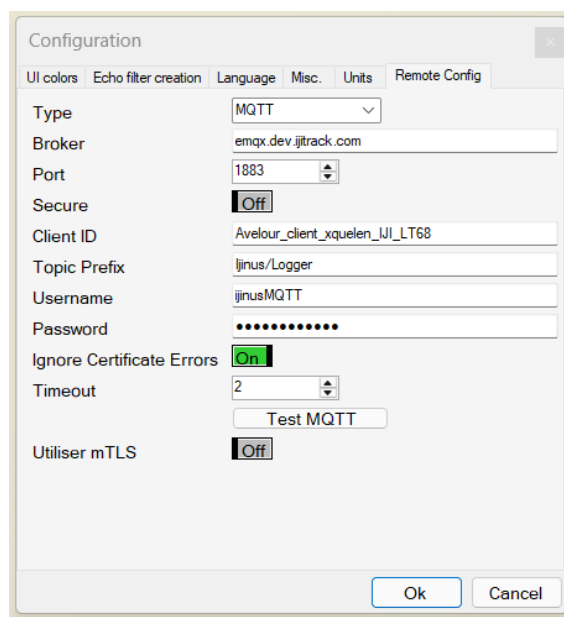

Configuration

UI colors Echo filter creation Language Misc. Units Remote Config

Type

Broker

Port

Secure

Client ID

Topic Prefix

Username

Password

Ignore Certificate Errors

Timeout

Utiliser mTLS

9.8.3. Configuring data sending

The use of an FTP server is required to perform remote configuration or firmware updates with internet data sending via FTP, Coap, HTTPS or MQTT.



It is necessary to configure remote FTP in the Avelour options.

If you are using another server, contact Ijinus to obtain a version of Avelour that allows you to customize the server configuration.

- Activate **Internet data sending** and choose [FTP](#), [HTTP](#) ou [MQTT](#) protocol.

FTP

- Enter the access name in the **FTP Server** line by switching the **Default** button to **define**, and enter the access name (TEST in the example below).
- The password is managed automatically by Avelour, but you can enter it in the FTP Password line by switching the **“default”** button to **“define”** and then entering the password.
- The other settings for sending data must not be changed.

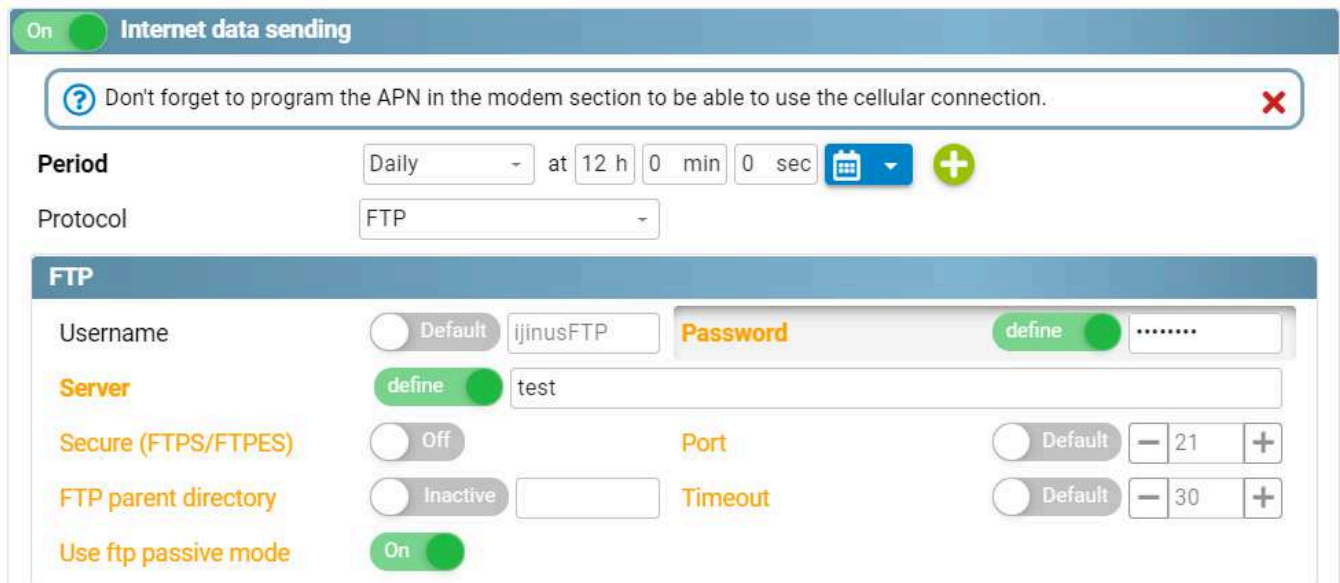

FTP configuration server with FTP protocole

HTTP

- Enter the same settings as those entered in the server access configuration. (???)



Authorization token correspond to API KEY

HTTP

Request format	?	ijinus	
Server	?	ijidegemer.dev.ijitrack.com	
Secured (HTTPS)	?	https <input checked="" type="checkbox"/>	Port ? <input type="text" value="8080"/>
Username	?	ijinus	
Authorization Token	?	*****	

MQTT

- Enter the same settings as those entered in the server access configuration. (???)

MQTT configuration

Server		emqx.dev.ijitrack.com	
Secured (MQTTS)	On <input checked="" type="checkbox"/>	Port <input type="text" value="1883"/>	
Username		ijinusMQTT	Password <input type="text" value="*****"/>
Quality of Service		<input type="text" value="2"/>	
Client ID		IJA0102-00000016	
Format		ijinus	

Topic

Topic format will be:

- ijinus/Logger/IJA0102-00000016/DATA/#
- ijinus/Logger/IJA0102-00000016/LOG/#

Topic Prefix

When choosing the **Almaviva** format, it is possible to enable **Send descriptor**, allowing the addition of a topic (/DESC), describing the correspondence between the recorded data channels and the "Var".

Format		Almaviva	Send descriptor <input checked="" type="checkbox"/>
--------	--	----------	---

Topic

For Almaviva format, topic structure will be:

- ijinus/Logger/IJA0102-00000016/HData
- ijinus/Logger/IJA0102-00000016/LOG
- ijinus/Logger/IJA0102-00000016/DESC

Topic Prefix

9.8.4. Retrieving a configuration via internet

To modify a settings remotely :

- Go in "Actions" menu and click on "Configure a device remotely"

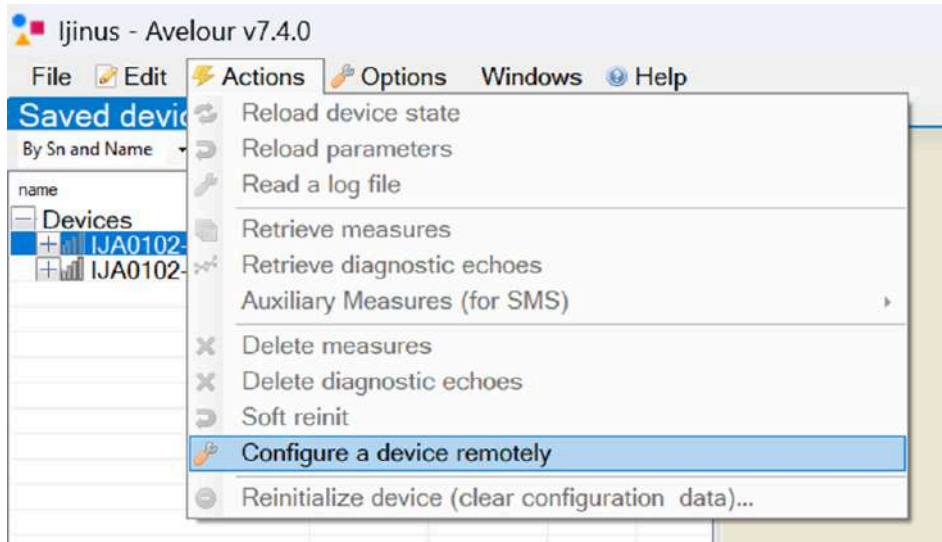

- Enter the serial number of the logger you want to modify remotely :

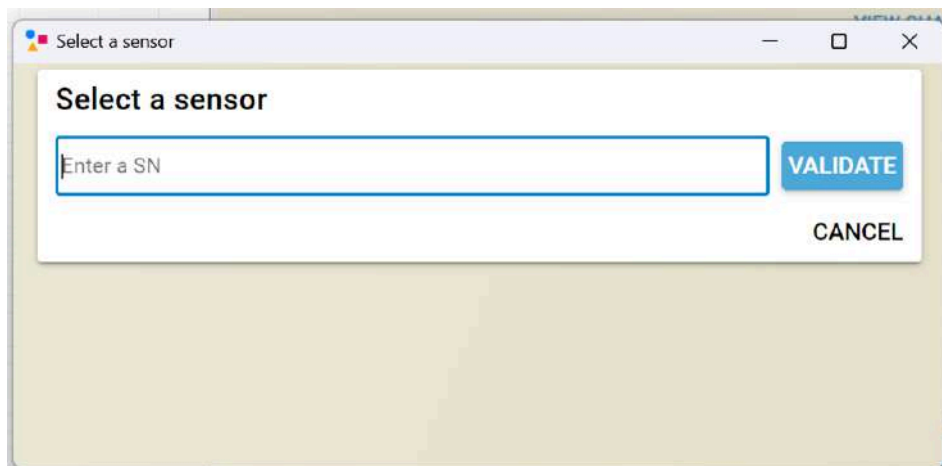

- In this page you can download data (1 week history), echo files, log, or the latest configuration on the broker.
- Click on download latest configuration to be able to modify the configuration.



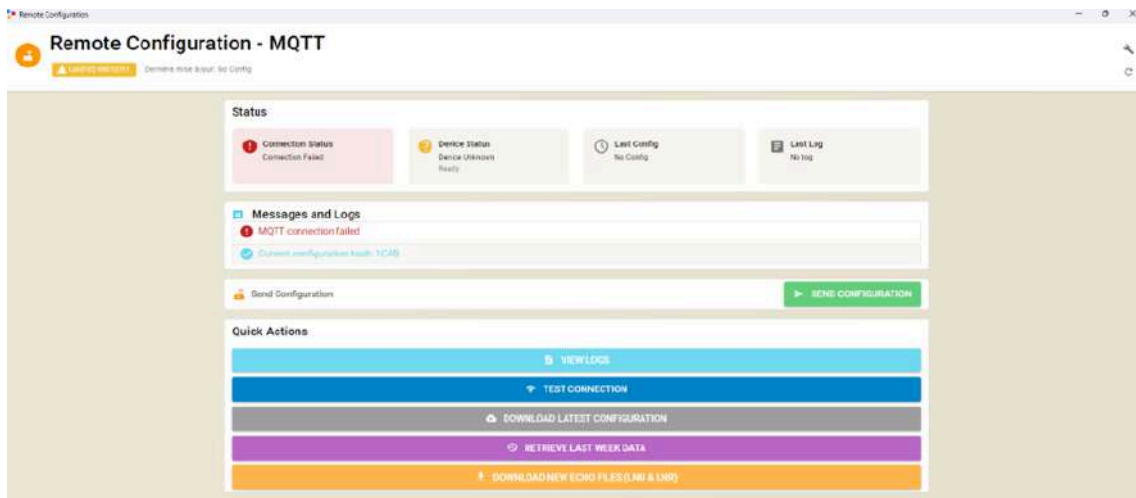

9.8.5. Edit and send the configuration remotely

In the saved data window:

- Open the configuration file for the relevant recorder :
 - Right-click on the configuration file and click on “Show.”
- or
- Double-click on the file.

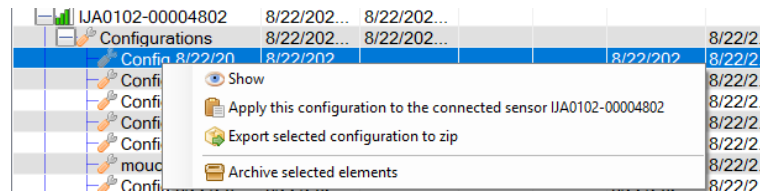

- Click on edit to exit the read only mode and modify the configuration.



- Once modified, click on one of the option : **SAVE CONFIGURATION OR SEND TO FTP** or **SAVE CONFIGURATION OR SEND TO MQTT SERVER** OR **SAVE CONFIGURATION OR SEND TO HTTP SERVER**.



- Enter a name to identify the new configuration that will appear in the saved data.
- Click on Save and send to remote server to upload the new configuration to the server.

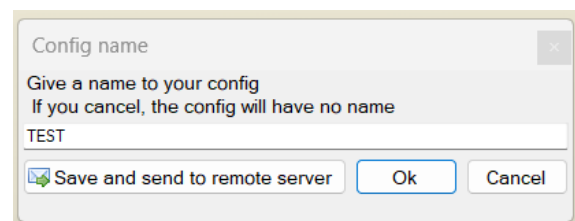

-> The remote configuration window opens, and Avelour connects to the server to verify that the logger has already deposited data on the server.

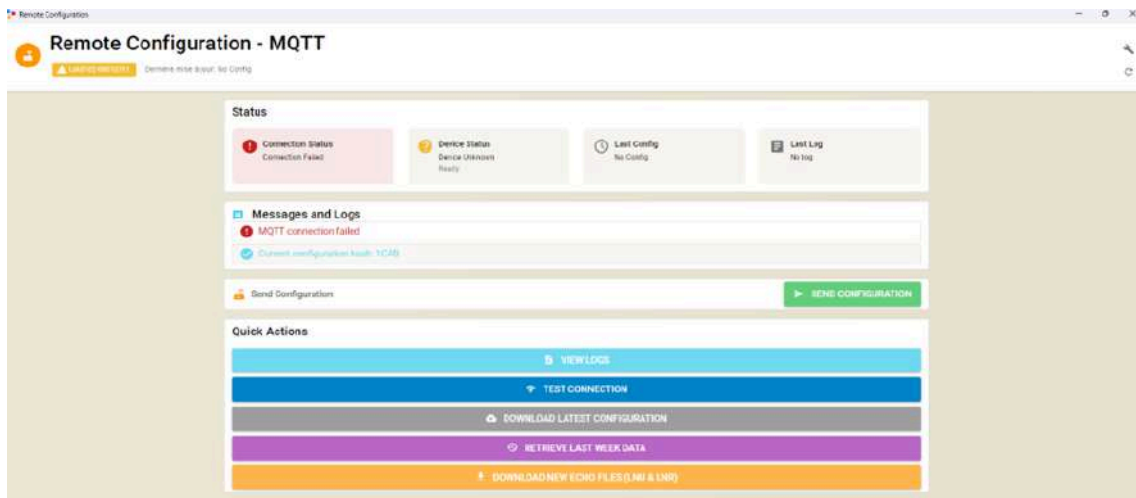

- Check the status and click on “Send configuration”.



Beware ! remote firmware status update and remote configuration can't be done simultaneously. Take care to launch one when the other is finished.



- The next time the recorder connects to the server to deposit data, it will download the file containing the modified configuration.
- A check is performed after the update to ensure that the change has been taken into account.

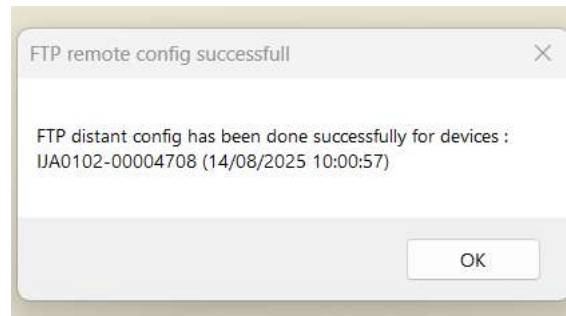

Update pop-up window

9.8.6. Do a remote configuration of a logger without a communication card

If the sensor whose configuration you want to modify does not have a communication card, you must specify the recorder to which it is paired (called the parent device) so that the configuration is first downloaded by the recorder and then sent via the radio link to the target sensor.

If the recorder, whose configuration you want to modify remotely, does not have a communication card, you must configure a recorder with a communication card (Master) to which the recorder will be paired. The configuration will first be downloaded by the master recorder and then sent via the radio link to the slave recorder.

- Edit the **Retrieve Device** feature in the master recorder configuration (with communication card and set up for sending data) by adding the slave recorder (without card). (See paragraph ???).

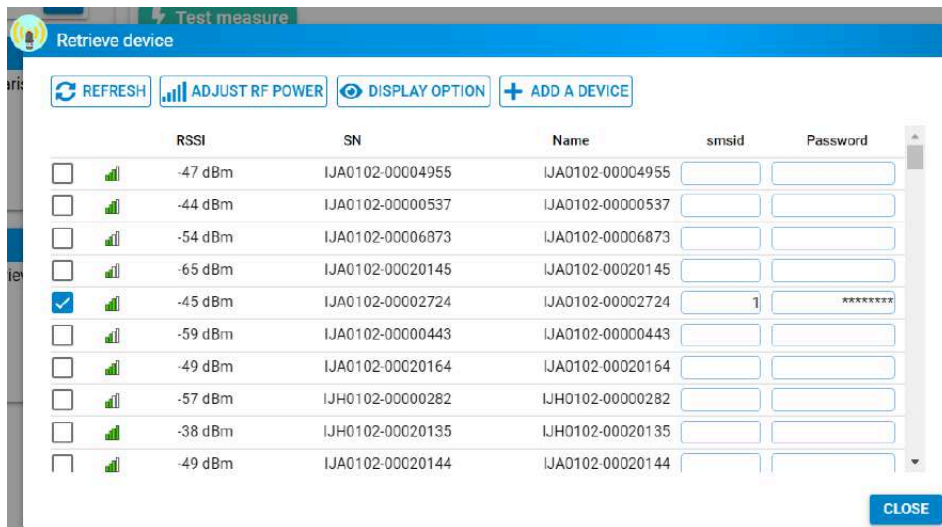

- Save the new configuration.

In the saved data window:

- Open the configuration file for the relevant recorder (without communication card):
 - Right-click on the configuration file and click on "Show."
 - or
 - Double-click on the file.

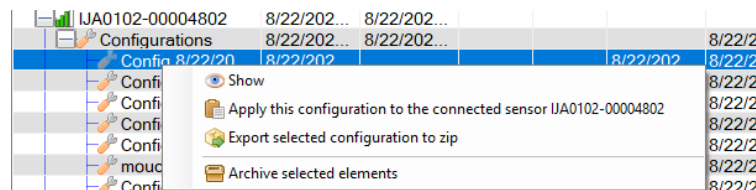

- Click on **EDIT** to exit the read only mode and modify the configuration.



- Once modified, click on one of the option : **SAVE CONFIGURATION OR SEND TO FTP** or **SAVE CONFIGURATION OR SEND TO MQTT SERVER** OR **SAVE CONFIGURATION OR SEND TO HTTP SERVER**.



- The next time the recorder connects to the server to deposit data, it will download the file containing the modified configuration.
- A check is performed after the update to ensure that the change has been taken into account, and a message is displayed on Avelour when data is sent for the first time.

9.9. Test data transmission before commissioning

9.9.1. Objective

Before commissioning an Ijinus datalogger equipped with a communication PCB, you must ensure it operates correctly in the field with the selected communication networks.

9.9.2. Test procedure

1. In the data transmission menu, click on the edit button, when the popup opens click on the wrench  in the top right to display the advanced settings.
2. Configure the modem part as shown below:



The screenshot shows a configuration window with the following fields:

- Technology to use:** LTE-M
- Region:** World
- Priority operator:** Active (toggle), 10000
- PIN code:** Active (toggle), [empty]
- APN:** lot.1nce.net
- PPP phone:** Inactive (toggle), [empty]
- PPP user:** Inactive (toggle), [empty]
- PPP password:** Inactive (toggle), [empty]

- Select “LTEM” technology only.
- Set the location to **world**.
- Enter the **APN** linked to your SIM card.
- Activate the priority operator: the space to enter the code is now available (you will need to know the operator code beforehand — see the list of operators in the country).

3. Program the modem. 

4. Run modem diagnostics .

5. Activate  data sending by Internet with the desired transmission cycle.

6. Start a data transmission test.

9.9.3. Troubleshooting

Network connection issues can occur at key stages of the test:

Problem	Step	Corrective action
Failed to connect to the network	4	<ul style="list-style-type: none"> • Change the priority operator and redo from step 3 on existing networks • Increase timeout from 120 s to 180 s (see image below) 
Failed to connect to SNTP server	6	<ul style="list-style-type: none"> • Check the APN code • Change the priority operator and try again

Connected to the SNTP server but failed to connect to the FTP	6	<ul style="list-style-type: none"> • Check the FTP server identifiers
---	---	--

9.10. Power supply configuration

The power supply is managed in the "System options" window.

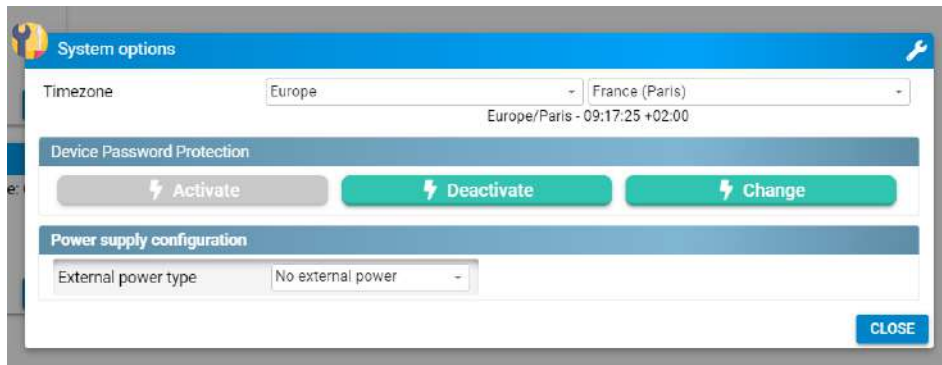

9.10.1. Lithium battery

The logger retrieves the voltage from the external power supply and stops measurements if a minimum voltage threshold is reached. This threshold depends on the type of external power supply and the rated voltage

Examples of thresholds:

- 10.8 V Lithium battery pack: $10.8 \times 0.8 = 8.6$ V.

To configure a 14.4-volt battery pack:

- In expert mode and advanced settings , change the rated voltage from 10.8 to 14.4 V. The threshold for stopping measurements will be $14.4 \times 0.8 = 11.5$ V.

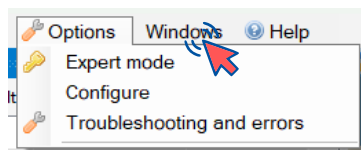

Connector power supply: Select whether the probe is powered directly from the external battery or from the logger's internal power supply, in which case the **voltage applied to the output** can be set between 5 and 18 Volts.

Record external power supply voltage: Enables remote monitoring of pack charge.



You must connect to the logger so that it can take measurements with the external sensor connected.

9.10.2. Lead-acid battery

The logger collects the voltage data from the external power supply and stops measurements if a minimum voltage threshold is reached. This threshold depends on the type of external power supply and the rated voltage.

Examples of thresholds:

- 12 V lead-acid battery: $12 \times 0.875 = 10.5 \text{ V}$.



For a lead-acid battery and if the logger has been configured with a lead-acid battery, you do not need to connect to the logger via Avelour.

To configure a 12-volt battery pack:

- In expert mode and advanced settings  change the nominal voltage to 10.5 V

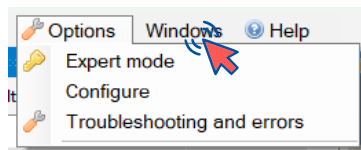

- Reconnect a recharged battery and the logger will resume its operating cycle.

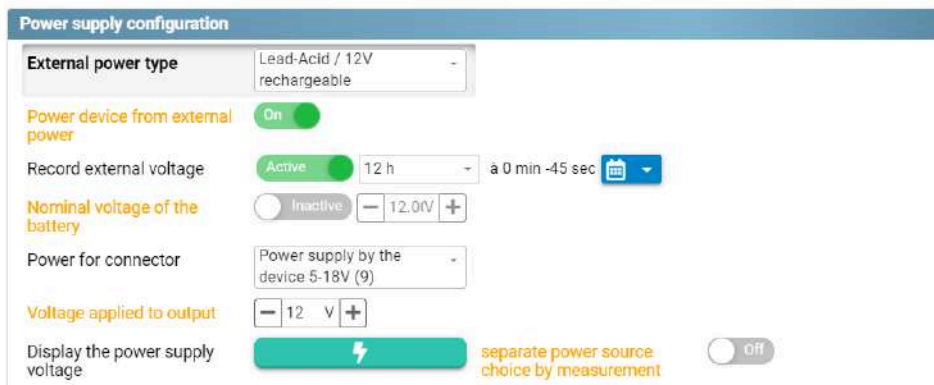

Connector power supply: Select whether the probe is powered directly from the external battery or from the logger's internal power supply, in which case the **voltage applied to the output** can be set between 5 and 18 Volts.

Record external power supply voltage: Enables remote monitoring of pack charge.

9.11. Set time zone

In the "System Options" window:

- Click on the drop-down menu to select the desired time zone (Europe in the example below).
- Select the city corresponding to the desired time zone.

-> The time that will be applied to the logger is then recalculated automatically.

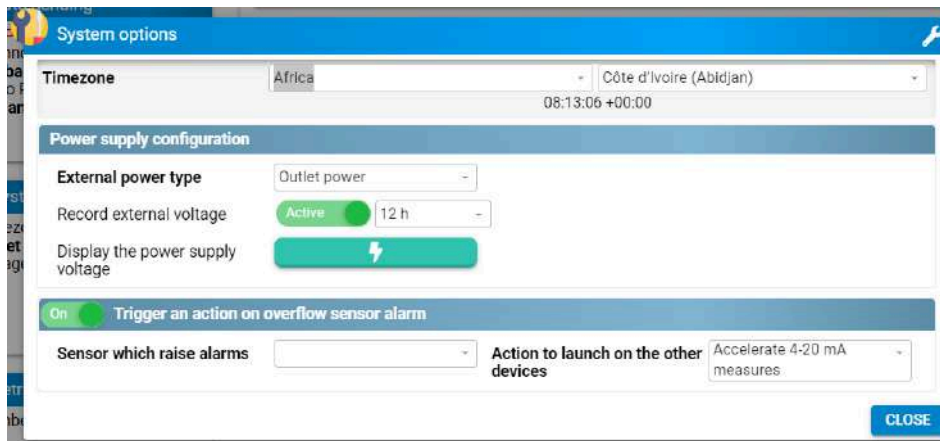

9.12. Pairing one or more loggers

In addition to its measurement capability, a logger can also be used as a hub (or master logger). In fact, it can retrieve data from another logger wirelessly and by radio, if they are less than 25 m apart in an unobstructed open field, or if one is in a manhole, under a metal cover and the other is not (in this case, the distance between the two hubs must be less than 5 m). The "master" logger then retrieves data from a "slave" logger. This option is called pairing and is configured in the "master" logger. No settings are required on the slave logger.

In the "Retrieve devices" block:

- Click "EDIT".

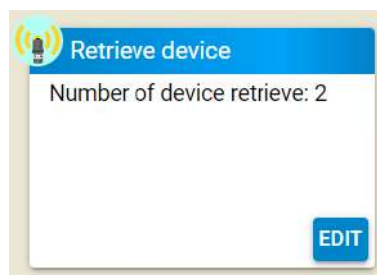

- Select one or more loggers from the list.

-> the software generates an **smsid** to identify data from each paired logger when sent by SMS.



The channel number used by some supervisors to associate equipment data is 0 by default (i.e. cannot be modified via software) for a "master" logger. The channel numbers of paired loggers are set by the "sms id" (here, for example, 1). Each paired sensor will therefore have a different sms id.

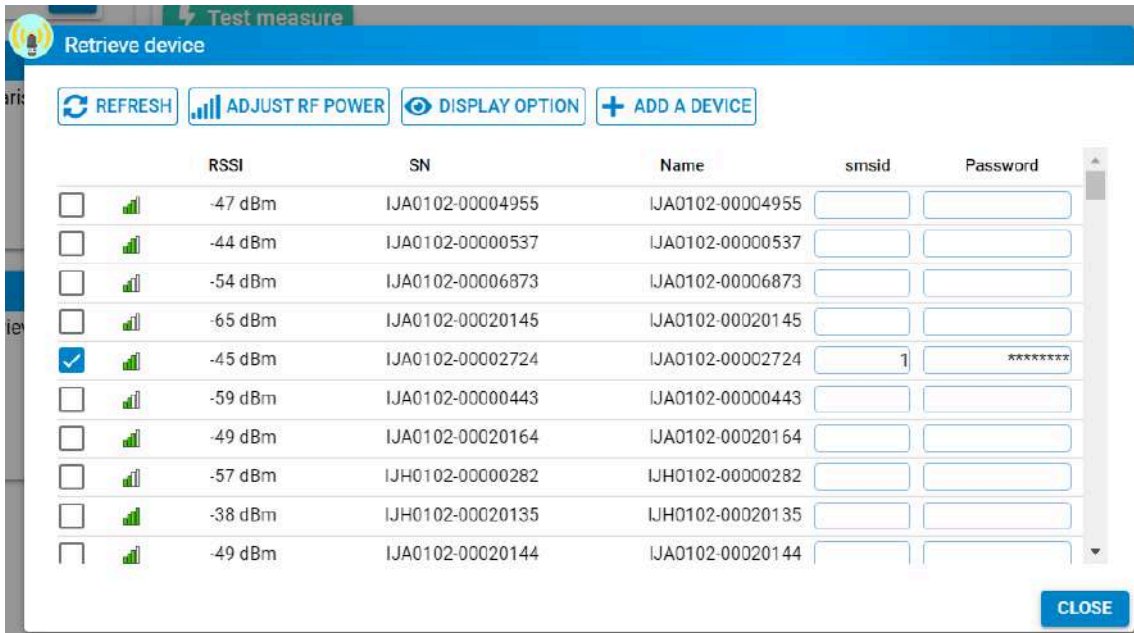

- If the sensor you are looking for is not available, click the "refresh" button to update the page.

9.13. Check the status of data recording and transmission

In the configuration window, two icons allow you to control the status of data recording and transmission.

A : Current status

B : Status after loading the configuration on the logger, useful information to check if the configuration being edited is correctly configured.

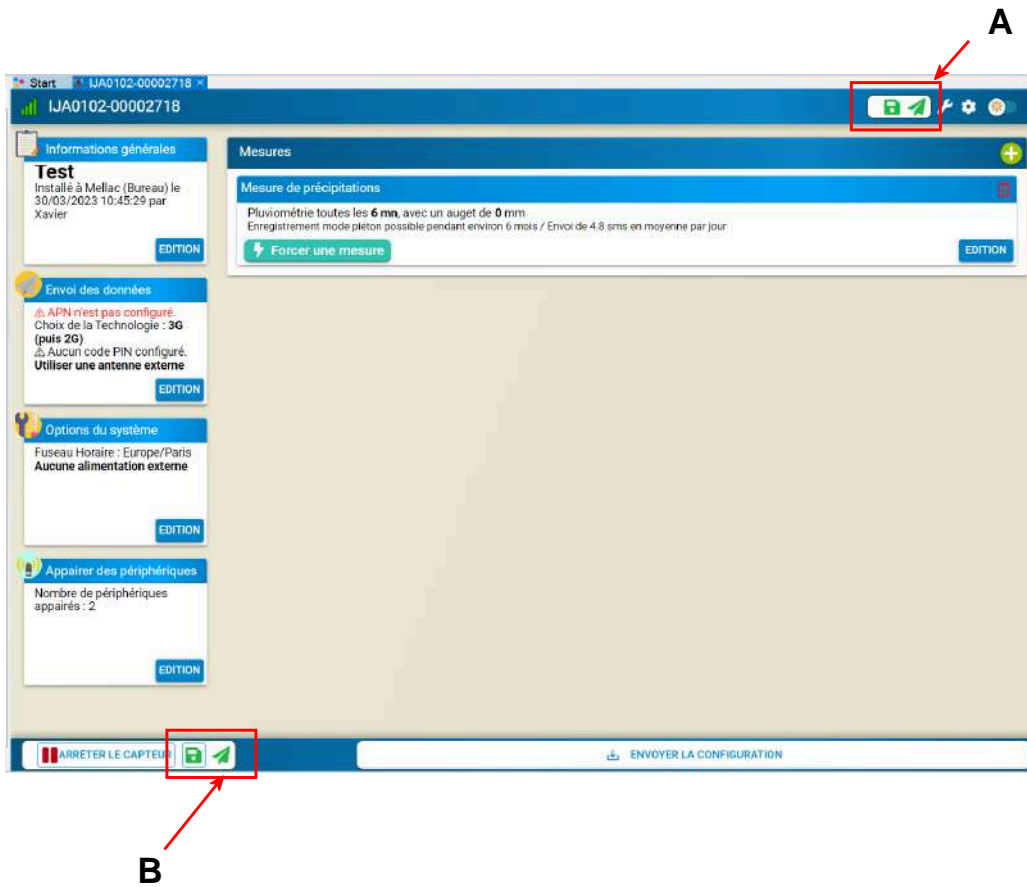

No data are being recorded



No data are being transmitted



Data are being recorded



Data are being transmitted

9.14. Save the configuration to the logger



Prerequisites: The logger is connected to Avelour (see [Connecting to the logger](#)).

To save all the settings configured on the logger:

- Click "SEND CONFIGURATION".

 **SAVE CONFIGURATION**

-> An update loading window is displayed.

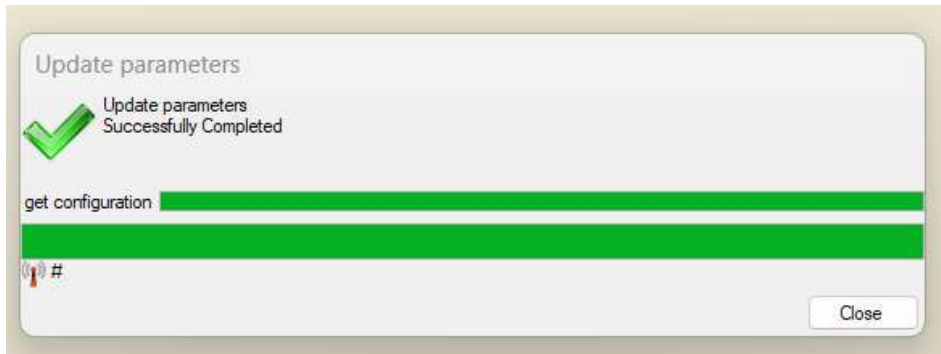

-> Data recording is activated and its status is visible via the  icon located at the top right of the configuration window (see paragraph [Check the status of data recording and transmission](#)).

-> Data transmission is activated and its status is visible via the  icon located at the top right of the configuration window (see paragraph [Check the status of data recording and transmission](#)).

9.15. Viewing measured data in real-time

All the measured parameters can be viewed in real time.

- In the windows tab, click on "View Broadcast measure".

-> The "broadcast measures" window is displayed.

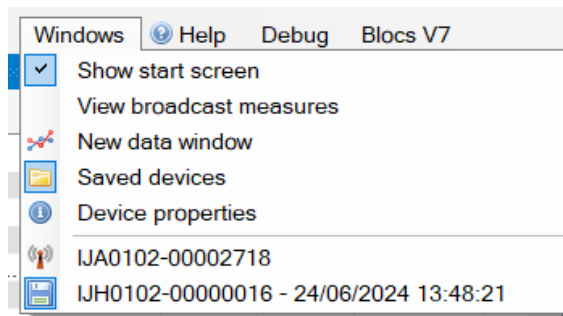

SR	Name	LastDate	Current	Release	Credits	Velocity	Measure	H2S Co.	Calibrat.	Debug L	Debug R	Rpm (st)	Debug L	Value	Doppler	Doppler	Doppler	Counter	Water	State	Measure	Display	Display	Display	Velocity	Measure	PKU Tu
1	IJA0102-00002718	24/06/2024 13:48:21					21	0																			
2	IJA0102-00000046	24/06/2024 13:48:21																									
3	IJA0102-00004827	24/06/2024 13:48:21																									
4	IJA0102-00004725	24/06/2024 13:48:21																									
5	IJA0102-00000622	24/06/2024 13:48:21																									
6	IJA0102-00000020	24/06/2024 13:48:21																									
7	IJA0102-00000057	24/06/2024 13:48:21																									
8	IJA0102-00004801	24/06/2024 13:48:21																									
9	IJA0102-00000075	24/06/2024 13:48:21																									
10	IJA0102-00000032	24/06/2024 13:48:21																									
11	IJA0102-00001860	24/06/2024 13:48:21																									
12	IJA0102-00001145	24/06/2024 13:48:21																									

Window showing the measurements received by radio from Ijinus sensors and loggers nearby.

9.16. Configuration managing

9.16.1. Creating a configuration template

- Connect to a logger and open an existing configuration via the saved data window.

- In the "Edit" menu, click on "Save device configuration as template".

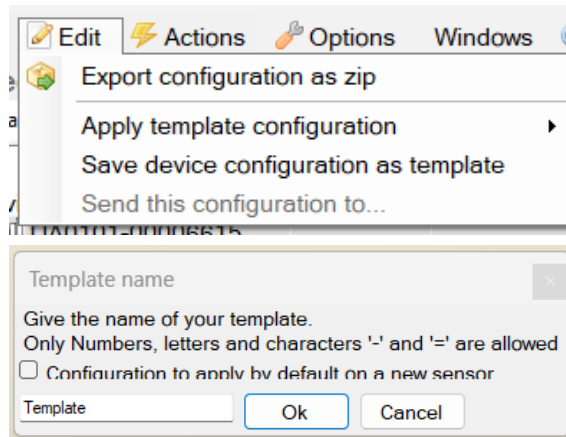

- Tick the "Configuration to be applied on a new sensor" option so that the template is applied automatically when a new logger is connected.
- Enter a name and click "Ok".

-> An .IJCZ file is created in the following directory: C:\ProgramData\Ijinus\Avelou_Main_7.xxxxx\userTemplates.

-> The template created is available in the "Edit" menu.

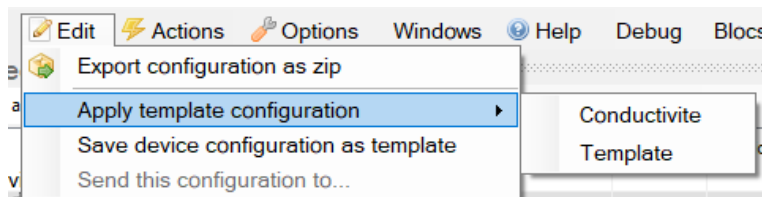

9.16.2. Applying a template configuration



The template created is available in the "Edit" menu. See [Creating a configuration template](#).

- Connect to the logger to which a model is to be applied (See [Connecting to the logger](#)).
- In the Edit menu, select the desired template in the "Apply template configuration" list.

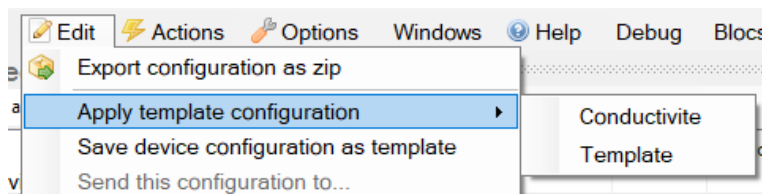

9.16.3. Archiving a configuration file

In the "Saved devices" window :

- Right-click on the configuration file to be archived and click on "Archive selected item".

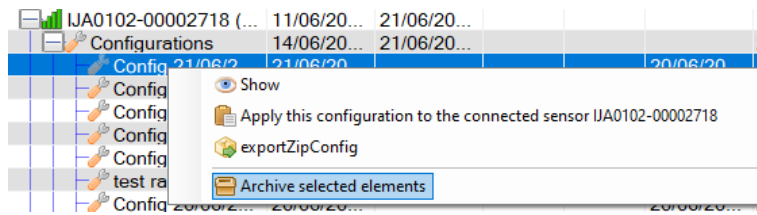

->The item is no longer displayed.

- To display the archived configuration file, click on "device items" and click on "Show archived items".



-> The item is now strikethrough.

- To unarchive it, do a right-click and select "unarchive selected items".

9.17. Stopping a recording in progress

- Click on "Stop device" to stop recording.



-> Recording and data transmission are stopped.  

- To restart the measurement, click on the "restart device" button.



9.18. Disconnecting from the logger



The disconnection with the logger is done automatically after a few minutes when no data is transferred.

To force a disconnection with a logger:

- Close the configuration window by clicking on the cross.



Chapitre 10. Managing recorded data on Avelour

10.1. Retrieving recorded data (Auxilliary memory)

To download data locally with a logger programmed to send data by M2M or SMS :

- In the actions menu, select "Auxiliary measures (for SMS) > Retrieve measures".

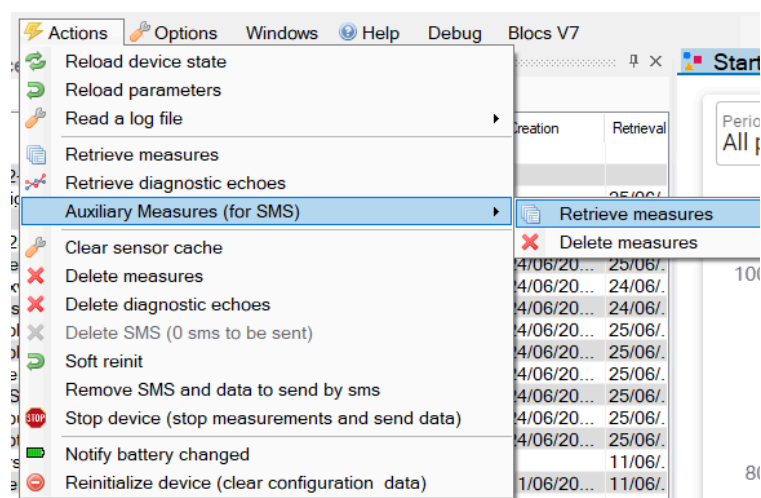

10.2. Retrieving recorded data (Main memory)

To retrieve data of the main memory:

- Connect to the logger (See paragraph [Connecting to the logger](#)).
- Click on "Retrieve without deleting" to keep the data in the logger's memory or "Recover and delete" to empty the logger's memory.



Or

- In the "Actions" menu, click on "retrieve data".

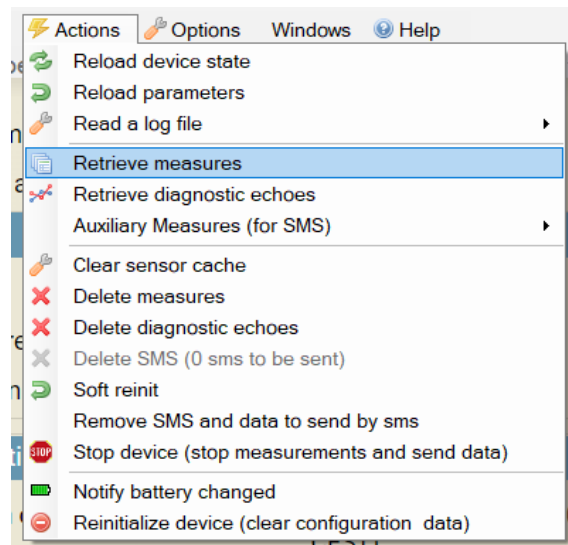

-> The window displaying the data graph opens.

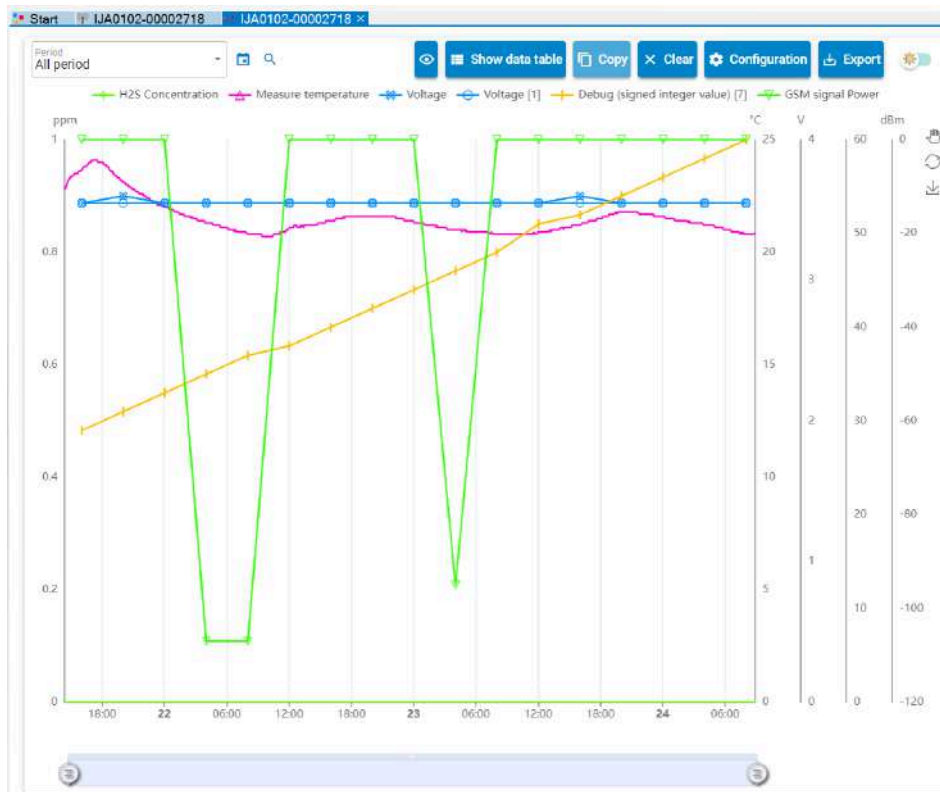

Data graph window

-> In the "Saved devices" window, the recovered data appears in the tree structure.

name	First	Last	Data ty...	Records	Creation	Retrieval
IAA0102-00002718 (...)	11/06/20...	24/06/20...				
Configurations	24/06/20...	24/06/20...				24/06/...
Data	24/06/20...	24/06/20...				24/06/...
H2S Concentra...	24/06/20...	24/06/20...	0038[...]	40	24/06/20...	24/06/...
Measure temp...	24/06/20...	24/06/20...	0012[...]	40	24/06/20...	24/06/...
Oxygen saturat...	24/06/20...	24/06/20...	0028[...]	39	24/06/20...	24/06/...
Dissolved oxyg...	24/06/20...	24/06/20...	0029[...]	39	24/06/20...	24/06/...
Voltage	24/06/20...	24/06/20...	0006[...]	1	24/06/20...	24/06/...
Voltage [1]	24/06/20...	24/06/20...	0006[...]	1	24/06/20...	24/06/...
Debug (signed...	24/06/20...	24/06/20...	0003[...]	1	24/06/20...	24/06/...
GSM signal Po...	24/06/20...	24/06/20...	0017[...]	1	24/06/20...	24/06/...
Filter	11/06/20...	11/06/20...				11/06/...

10.3. Displaying data on graph window

In the "Saved devices" window :

- Double-click on the data file to be displayed.

Or

- Select one or several data, right-click and click on 'View' to display the data in a graph window.

name	First	Last	Data ty...	Records	Creation	Retrieval
Meas...	20/06/20...	24/06/20...	0012[...]	1054	20/06/20...	20/06/20...
Voltaq...	20/06/20...	20/06/20...	0006[...]	22	20/06/20...	20/06/20...
Voltaq...	20/06/20...	20/06/20...	0006[...]	22	20/06/20...	20/06/20...
Debug...	20/06/20...	20/06/20...	0003[...]	22	20/06/20...	20/06/20...
GSM s...	20/06/20...	20/06/20...	0017[...]	22	20/06/20...	20/06/20...

-> The window displaying the data graph opens.

10.4. Data graph

10.4.1. Tools graph on Avelour



Inverts data selection displaying: masked data is displayed and displayed data is masked.

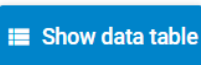

Displays a table of all data below the graph.



Copies data to clipboard for pasting.

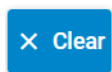

Clears data from graph





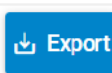

Enables access to the graph display customization window. See [Customising the graph display](#)







Allows you to export data in various formats (Excel, Ieme, CSV...) to a directory.



The data label allows one click to show/hide it.

- 
Switches between day (light) and night (dark) display modes.
- 
Zooms in/out on the grap: Click and hold to select the area you want to zoom in on.
- 
Allows to move over the graph with the mouse: click, hold and move.
- 



Hold down the mouse wheel button to activate hand mode.
- 
Restores the initial display of the graph.
- 
Exports the graphic as a PNG image.
- 
Zoom slider for x-axis.

10.4.2. Displaying the data graph

In the saved data window :

- Double-click on the data or select several item of data, right-click and click on 'Show' to view the data in graphical form.

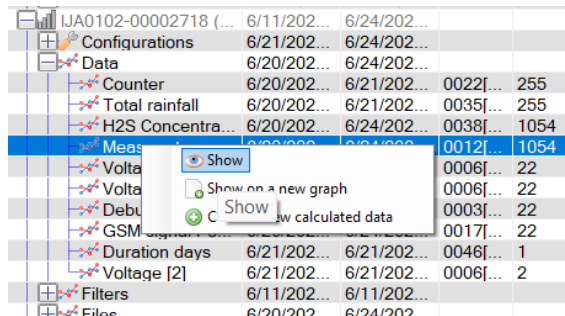

	6/11/202...	6/24/202...		
Configurations	6/21/202...	6/24/202...		
Data	6/20/202...	6/24/202...		
Counter	6/20/202...	6/21/202...	0022[...	255
Total rainfall	6/20/202...	6/21/202...	0035[...	255
H2S Concentra...	6/20/202...	6/24/202...	0038[...	1054
Meas	6/20/202...	6/24/202...	0012[...	1054
Volta			0006[...	22
Volta			0006[...	22
Debu			0003[...	22
GSM			0017[...	22
Duration days	6/21/202...	6/21/202...	0046[...	1
Voltage [2]	6/21/202...	6/21/202...	0006[...	2
Filters	6/11/202...	6/11/202...		
File	6/20/202...	6/24/202...		

-> The window displaying the saved data graph.

10.4.3. Customising the graph display

In the window displaying saved data :

- Click on the  button to display the graph display properties window.

Graph configuration
✕

DATA

Material height

+ Add a calculated data

- Remove data

Round values

AXES

Representation type
Line Color

Unit
mm

Symbol
Aléatoire ?

Line type
Standard

Filling

Line Width - 2 +

Linked axe : mm

Unbound axes

- 4 +
Maximum fraction digits number

10.4.4. Hide the display of a data item on the graph

- To hide the display of a data, click on the description of the data above the graph.

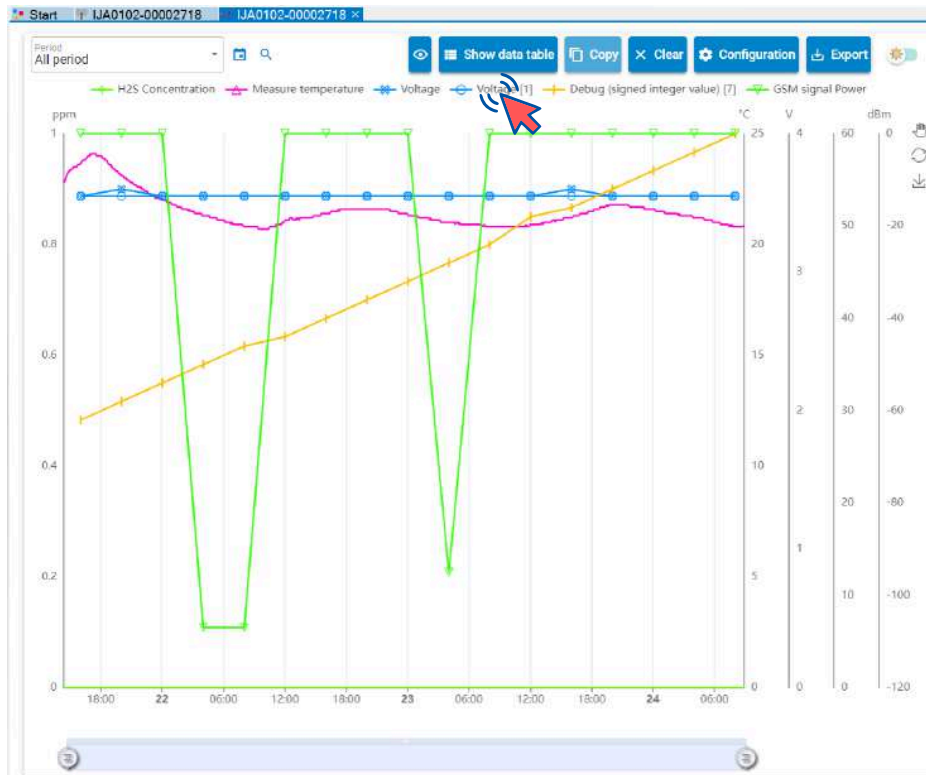

->The data graph is no longer displayed

- Click on the  button reverses the display, the displayed data is hidden and the hidden data is display.

10.4.5. Displaying table data

In the saved data view window:

- Click on the  button.

->Data are displayed under the graph

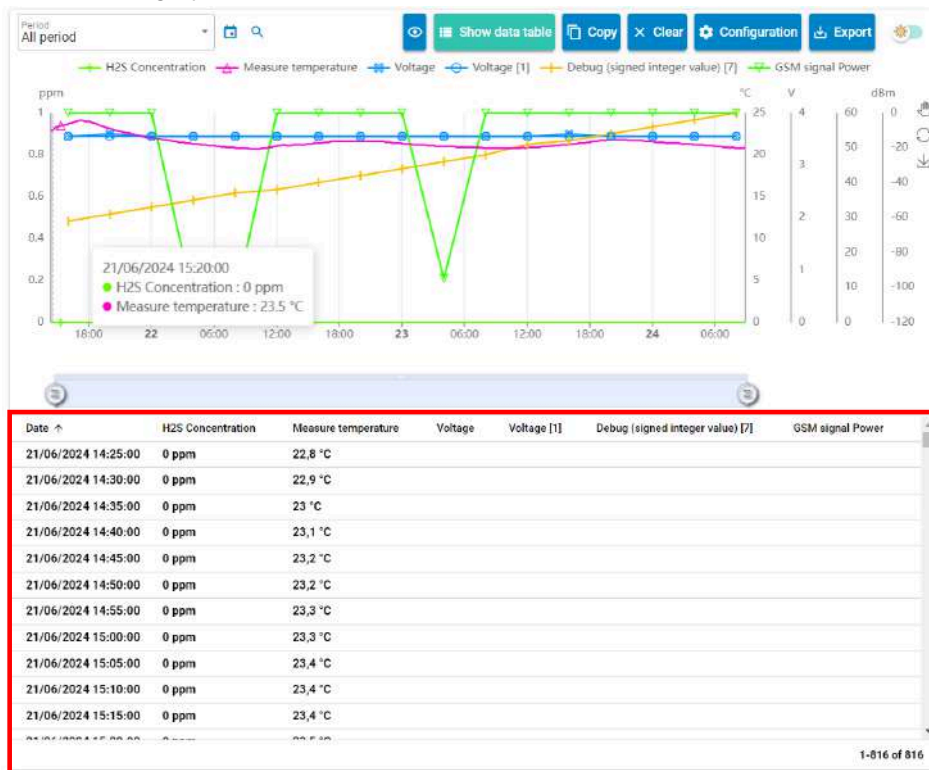

10.5. Exporting retrieved data



Data are retrieved in Avelour, see paragraph [Retrieving recorded data \(Main memory\)](#).

The display window containing the data is opened.

- Click on "Export".
- Select the type of export, the period and the destination directory and click on "Begin export"

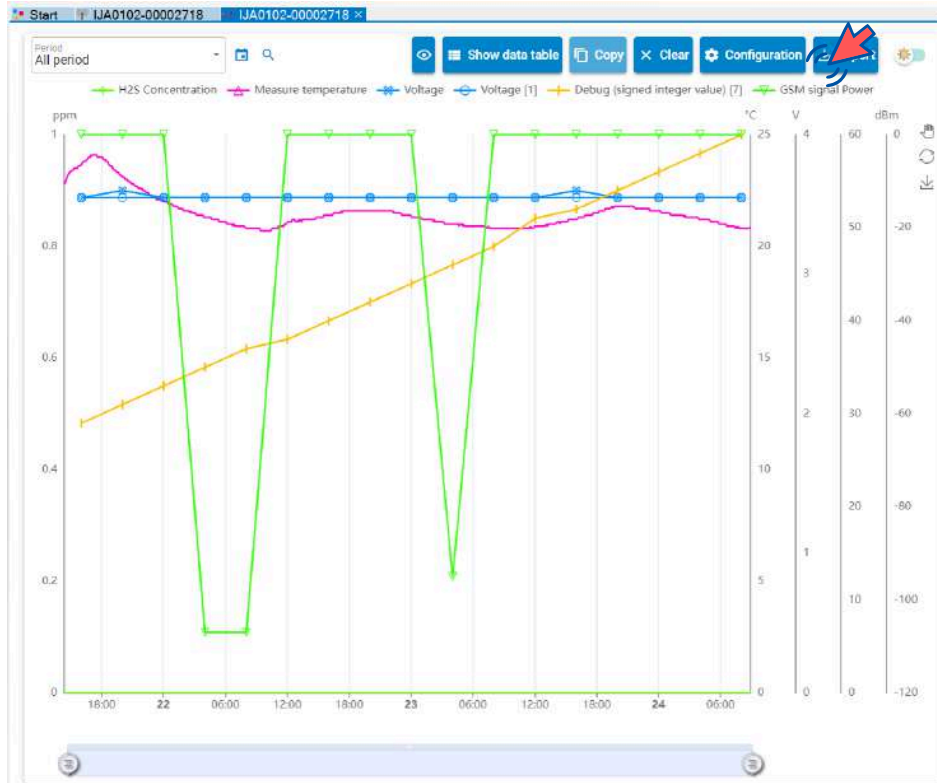

Data graph window - Exporting data

10.6. Delete data memory on the logger

- In the "Actions" menu, click on "delete measures" to delete the main memory of the logger.
- In the "Actions" menu, click on "delete measures" in the "Auxiliary Measures (for SMS)" sub menu.

Chapitre 11. Maintenance

If you have a problem with an Ijinus logger or sensor, we recommend that you contact our after-sales service either by e-mail : sav@ijinus.fr or by phone : 02.98.09.03.32

You will be given instructions on how to proceed, either to carry out tests on the product concerned, or to send it back to the factory for testing on our premises.

11.1. Replace the battery

When the logger's battery is at the end of its life, a red banner appears on Avelour inviting you to replace the battery.



Do not leave the logger open for too long (just a few minutes) because if the desiccant bag absorbs too much moisture, it will no longer be effective and its colour will turn green.

- Open the case by unscrewing the 4 screws on the rear of the case and then unclipping the 4 clips on the front of the housing.
- Check the colour of the desiccant bags (A) and replace them if they are green.
- Partially remove the board support (B) from the housing to gain access to the battery connector at the rear of the electronic board.
- Remove the old battery from its housing and disconnect it from the circuit board
- Connect the new battery to the circuit board (the connector (C) is keyed) then place the battery in its housing.

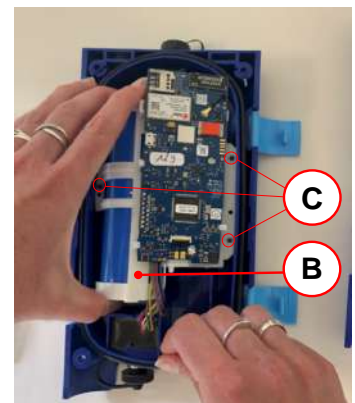
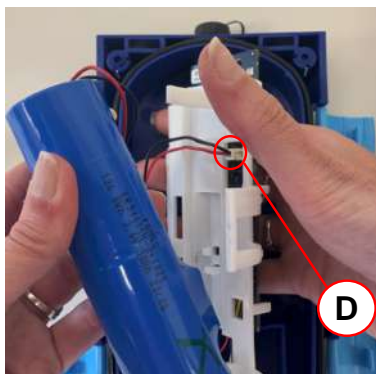
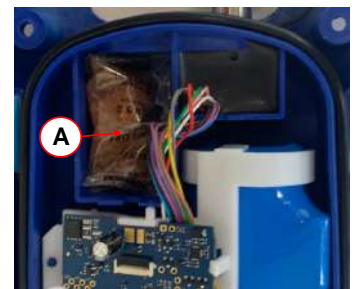

-> When the electronic board is restarted, the LED on the front of the board should flash red/green and then, after 2 to 3 minutes, only one green flash every 10 seconds.

- Replace the card holder in the slots provided.
- Close the logger, taking care not to put any electrical wires or objects between the front of the case and the seal (D) on the rear.
- Close the housing with the 4 clips and, if necessary, fit the 4 screws.



For outdoor installation, we strongly recommend to use the 4 screws supplied with the logger to ensure that the housing is watertight and to prevent deformation caused by temperature variations and bad weather.

- In Avelour, click on "battery changed" in the red banner.

If the battery has been changed before the red band appears, it is also necessary to notify the change of battery:

- Connect to the logger (see [Connecting to the logger](#)).
- In the actions menu, click on "notify battery change" to restart the logger and return the energy gauge to 0.

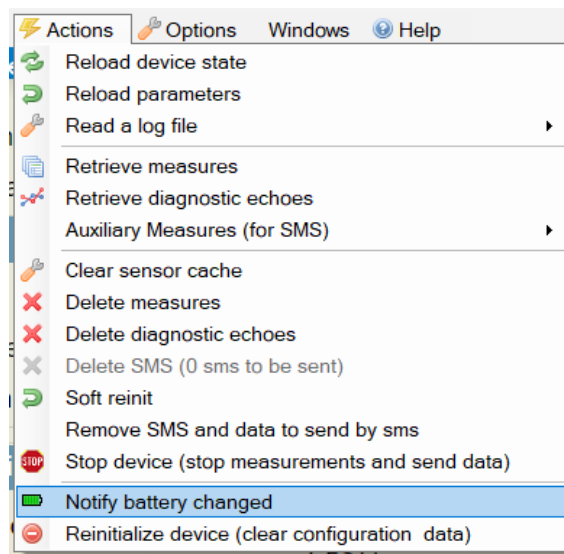

-> In the Device properties window, the battery gauge changes to 0.

Diagnostic	
Date on device	2024-06-20 17:09:24 (+02h00 CEST)
Battery	3.6V
Gauge	0mAh
Free memory	1007200 / 3243616 (31%)
Aux data	1
Main data	0

11.2. Reset the logger (factory settings)

The logger may need to be reset when a service request is made or if the password is forgotten.



The Reset process deletes all configuration files and data stored on the logger.

11.2.1. Wiji reset

- Connect to the logger (see [Connecting to the logger](#)).
- In the **Options** menu, click on **Diagnostics and errors**.
- Check that the serial number (1) corresponds to that of the logger.
- Check **Equipment reset (loss of data and configuration)** (2).
- Click on **Launch** (3).

-> the logger formatting window appears.



Depending on the amount of data to be deleted, the reset process may take a few minutes.

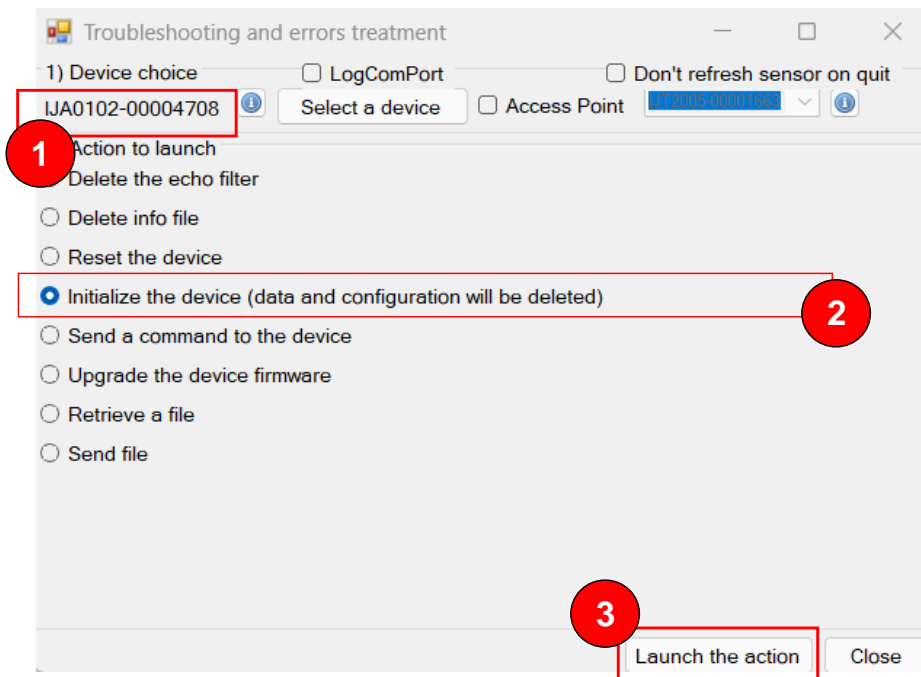

11.2.2. Manual reset



Avoid leaving the logger open for too long (just a few minutes), because if the desiccant bag absorbs too much moisture, it will no longer be effective and will turn green.

- Unscrew the clamping ring completely to fully remove the cover.
- Press the **SW (A)** button, then the **RST (B)** button, and release the **RST** button.
 - > The status LED (**C**) flashes red.
- When the LED changes to flashing green, release the **SW (A)** button.
 - > Reset starts.

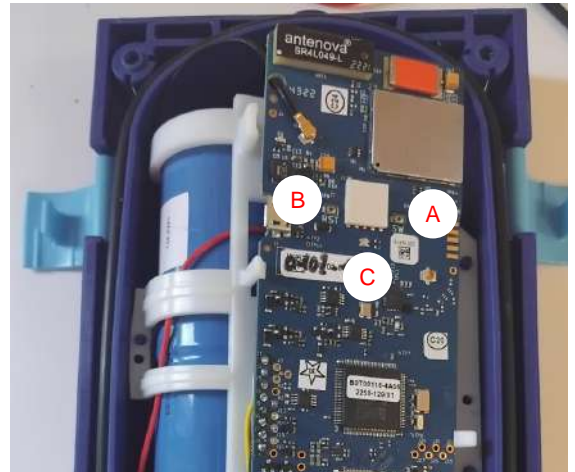

Depending on the amount of data to be deleted, the reset process may take a few minutes.

The LED resumes its initial flashing cycle (every 10 seconds in green) as soon as the reset is complete.

11.3. Firmware update

A firmware update may be required when updating the Avelour programming software.

- Connect to the logger (see paragraph [Connecting to the logger](#)).
- In the "Options" menu, click on "Troubleshooting and errors".
- By connecting to the logger in advance, the choice of device (1) is already made. To change this choice, click "Device choice".
- In the list of actions to launch (2), select "Upgrade the device firmware".
- Click "Choose firmware".

-> The Firmware folder opens.

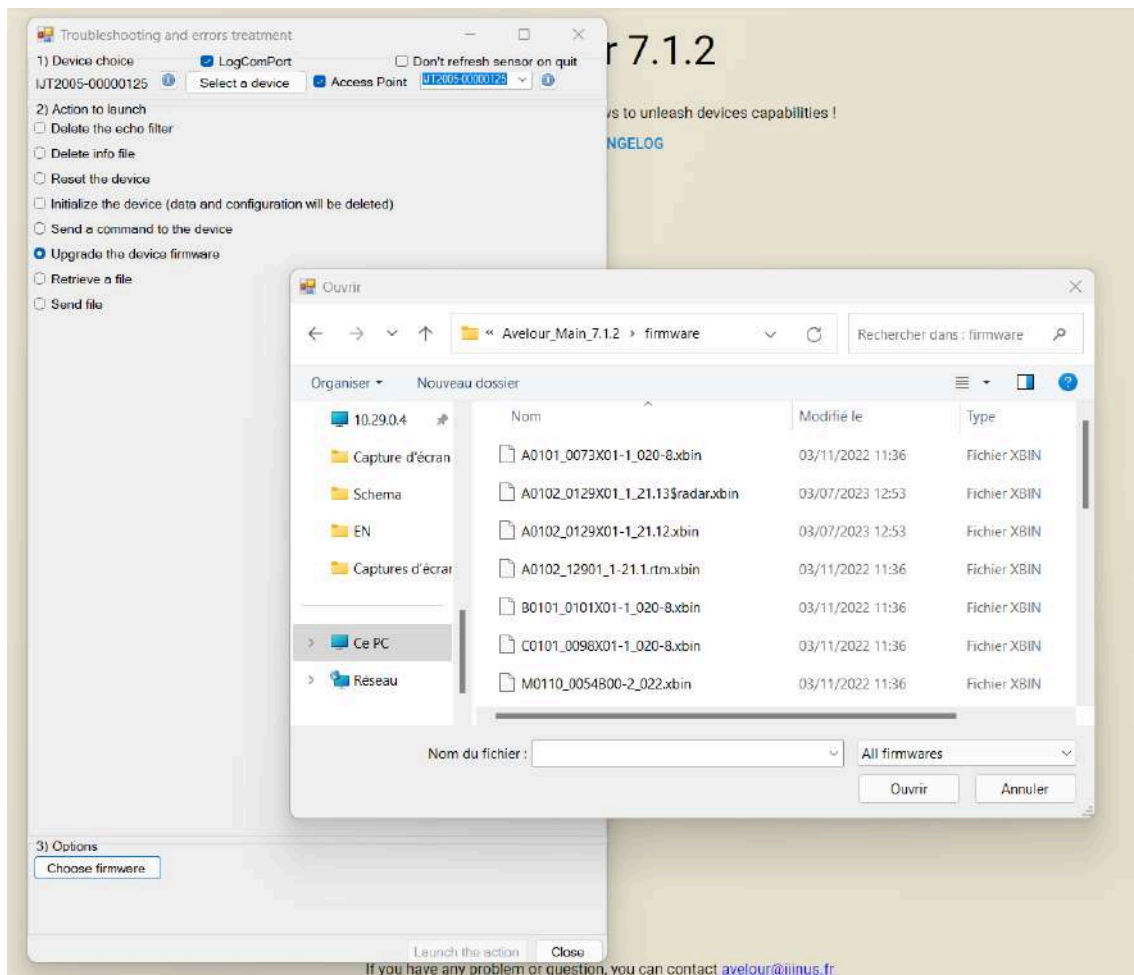

- Select the corresponding .xbin file and click "Launch the action" (3).

11.4. Remote firmware update



The logger must be equipped with a modem card and configured to send data via **FTP, HTTP or MQTT**.

If you are using the ijitrak server, contact Ijinus to obtain the identifiers and password and configure Avelour.

If using another server, contact Ijinus to obtain a version of Avelour enabling you to customize the server configuration.



Beware ! Remote firmware update and remote configuration can't be done simultaneously. Take care to launch one after the other.

- Hold down the CTRL key and select one or more loggers and right-click.
- Click on "Remote firmware update".

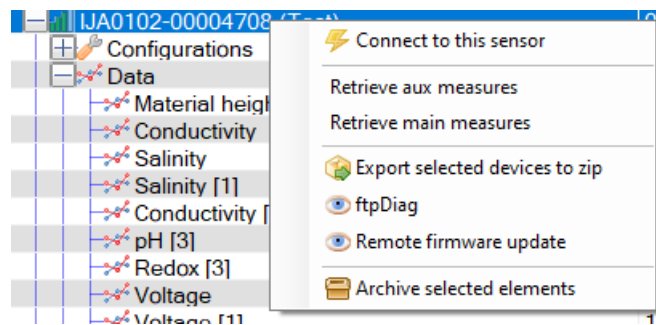

-> The update window opens and displays the firmware serial number(s), status, current version and new version.

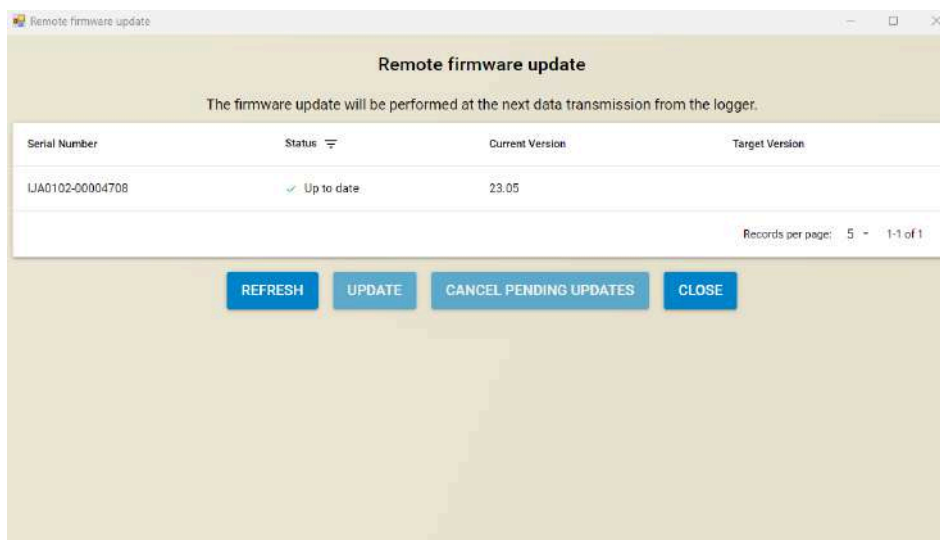

- Click "Update".

-> The update file is sent to the FTP server and the update will be performed during the next data transmission.